

SITE DEVELOPMENT PLANS

VESSEL MULTI-FAMILY HOUSING

446 HOPMEADOW STREET, SIMSBURY, CT 06089

PREPARED FOR: VESSEL RE HOLDINGS, LLC

DATE: DECEMBER 16, 2022
 REVISED: FEBRUARY 24, 2023
 REVISED: MARCH 17, 2023

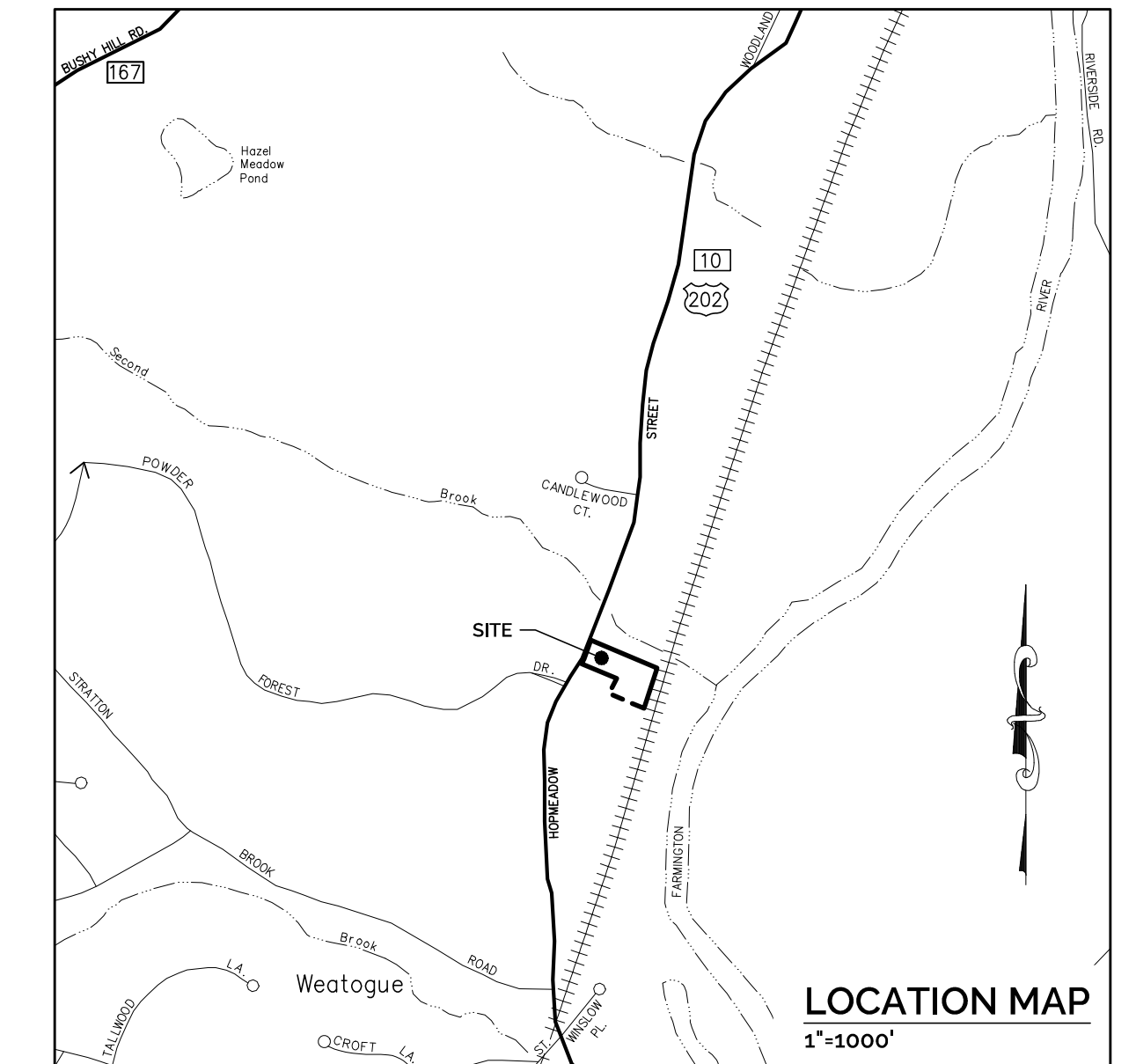

LEGEND

PROPERTY LINE	---
ADJOINER PROPERTY LINE	- - - -
BUILDING SETBACK LINE	---
ZONE LINE	---
WATERCOURSE	~~~~~
INLAND WETLAND	~~~~~
100' INLAND WETLAND UPLAND REVIEW AREA	~~~~~
TREELINE	~~~~~
BRUSHLINE	~~~~~
GUIDERAIL	---
CHAINLINK FENCE	X - X - X
EX. INDEX CONTOUR	-100-
EX. INT. CONTOUR	-99-
PR. INDEX CONTOUR	-100-
PR. INT. CONTOUR	-99-
PR. SPOT GRADE	7.5 ○
PR. SWALE	→
OVERHEAD ELECTRIC	OHE
UNDERGROUND ELECTRIC	UE
UNDERGROUND ELECTRIC, TELEPHONE, CABLE	ETC
SANITARY SEWER LINE	SAN
STORM PIPE	---
TELEPHONE LINE	TEL
WATER LINE	W
DOMESTIC WATER LINE	DW
FIRE PROTECTION LINE	FP
SILT FENCE	SF
HAYBALES	□ □ □ □ □
TOP OF WALL	TW
BOTTOM OF WALL	BW
TOP OF CURB	TC
BOTTOM OF CURB	BC
UTILITY POLE	○
IRON PIPE/IRON ROD	IP
BORING HOLES	B-2
TEST HOLES	TP-1

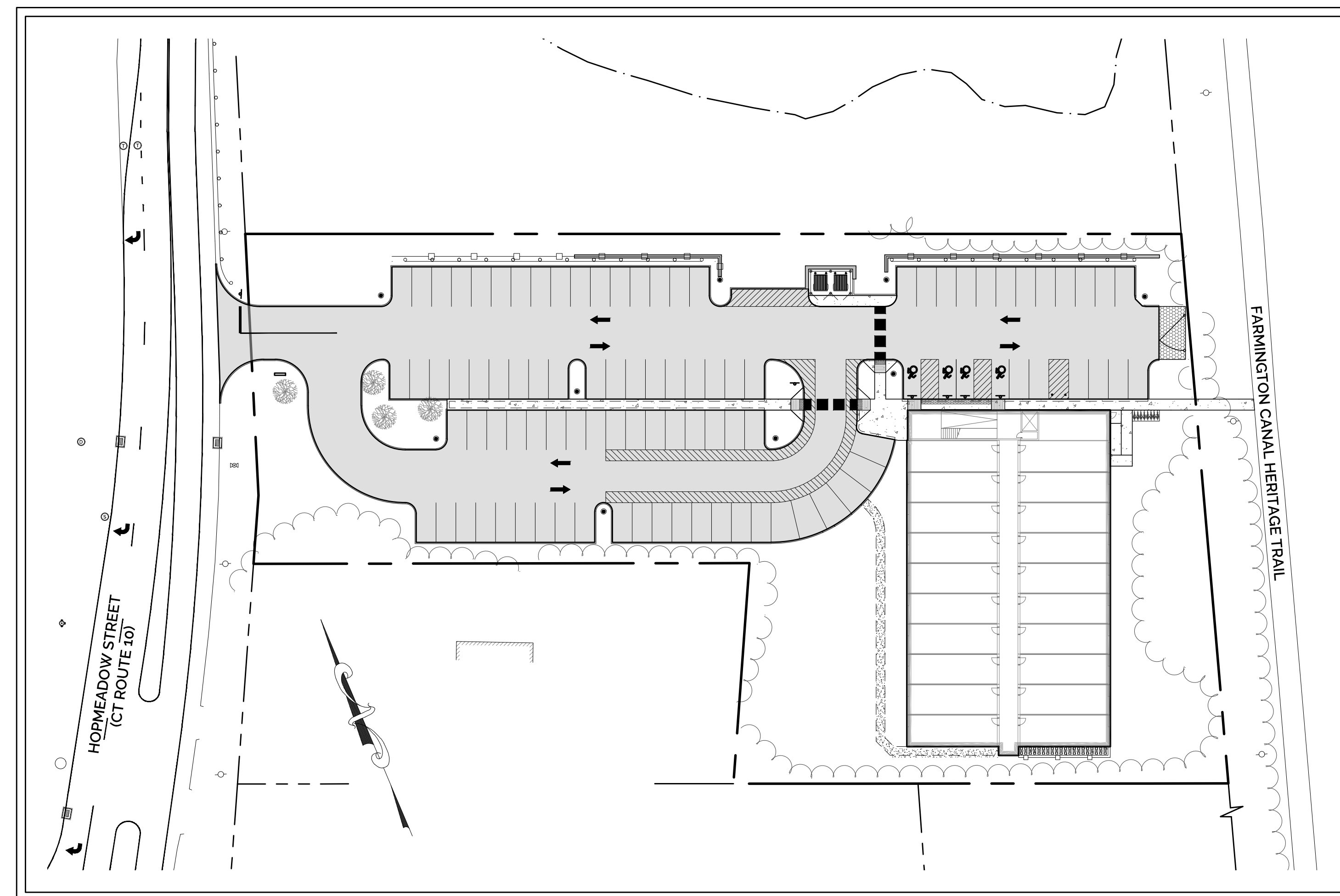

SHEET INDEX

DWG. NO.	TITLE	SHEET NO.
XD-1	EXISTING CONDITIONS & DEMOLITION PLAN	1
SL-1	SITE LAYOUT PLAN	2
GD-1	GRADING & DRAINAGE PLAN	3
UT-1	UTILITIES PLAN	4
SE-1	SOIL EROSION & SEDIMENT CONTROL PLAN	5
SPP-1	SITE PHOTOMETRIC PLAN	6
ST-1	SIGHTLINE DEMONSTRATION PLAN	7
SEN-1	SOIL EROSION & SEDIMENT CONTROL NARRATIVE AND DETAILS	8
DT-1	SITE DETAILS	9
DT-2	SITE DETAILS	10
DT-3	DRAINAGE DETAILS	11
DT-4	UTILITY DETAILS	12
DT-5	STORMWATER MANAGEMENT DETAILS	13
	PLANTING PLAN (BY OTHERS)	1 of 1

APPLICANT:
 VESSEL RE HOLDINGS, LLC
 46 WEST 55TH STREET
 NEW YORK, NY 10019

PROPERTY OWNER:
 EAY PROPERTIES LLC
 540 HOPMEADOW STREET #6
 SIMSBURY, CT 06070

CIVIL ENGINEER:
 H+H ENGINEERING ASSOCIATES, LLC
 SEAMUS MORAN, P.E.
 232 GREENMANVILLE AVENUE, SUITE 201
 MYSTIC, CT 06355

LANDSCAPE ARCHITECT:
 THOMAS GRACEFFA LANDSCAPE ARCHITECT, LLC
 19 FLAG DRIVE
 MANCHESTER, CT 06040

LAND SURVEYOR:
 ROB HELLSTROM LAND SURVEYING LLC
 32 MAIN STREET
 HEBRON, CT 06248

PREPARED BY:

H+H
 ENGINEERING
 ASSOCIATES

232 Greenmanville Ave.
 Suite 201
 Mystic, CT 06355
 860-980-8008
 www.hh-engineers.com

GENERAL CONSTRUCTION NOTES:

1. THE CONTRACTOR SHALL CONTACT "CALL BEFORE YOU DIG" AT 800-922-4455 TO MARK OUT ALL UNDERGROUND UTILITIES A MINIMUM OF 3 BUSINESS DAYS PRIOR TO COMMENCING ANY CONSTRUCTION ACTIVITY. CONTRACTOR SHALL VERIFY ALL LOCATIONS, DIMENSIONS AND ELEVATIONS OF ALL UTILITIES PRIOR TO CONSTRUCTION. IF UTILITIES DIFFER FROM THOSE SHOWN ON THIS PLAN, ENGINEER SHALL BE NOTIFIED.
2. ALL PROPERTY LINES SHALL BE VERIFIED IN THE FIELD. NO PRIVATE PROPERTY SHALL BE DISTURBED UNLESS PROPER RIGHTS ARE OBTAINED PRIOR TO CONSTRUCTION.
3. THE CONTRACTOR SHALL OBTAIN ALL REQUIRED PERMITS PRIOR TO CONSTRUCTION.
4. THE CONTRACTOR SHALL OBTAIN, REVIEW AND ADHERE TO ALL REQUIREMENTS AND ANY CONDITIONS OF APPROVAL OF THE TOWN OF SIMSBURY.
5. EXISTING DRAINAGE PATTERNS SHALL BE SUBSTANTIALLY MAINTAINED. THE CONTRACTOR SHALL GRADE THE PROPERTY IN SUCH A MANNER TO MAINTAIN EXISTING LOCAL DRAINAGE PATTERNS AND TO PREVENT EXCESS RUNOFF AND/OR PONDING ON ADJACENT PROPERTIES BOTH DURING AND AFTER CONSTRUCTION.
6. A CONNECTICUT DEPARTMENT OF TRANSPORTATION HIGHWAY ENCROACHMENT PERMIT IS REQUIRED FOR ALL IMPROVEMENTS, INCLUDING BUT NOT LIMITED TO APRONS, CURB CUTS, UTILITY LATERALS AND ROADWAY PAVEMENT PATCHING, WITHIN THE STATE RIGHT-OF-WAY.

STAMP

REV	DATE	DESCRIPTION OF REVISION	SHM	APPR.
2	3/17/2023	REVISIONS PER ENGINEERING REVIEW COMMENTS & IWA COMMENTS	SHM	
1	2/24/2023	REVISIONS PER REVIEW COMMENTS	SHM	

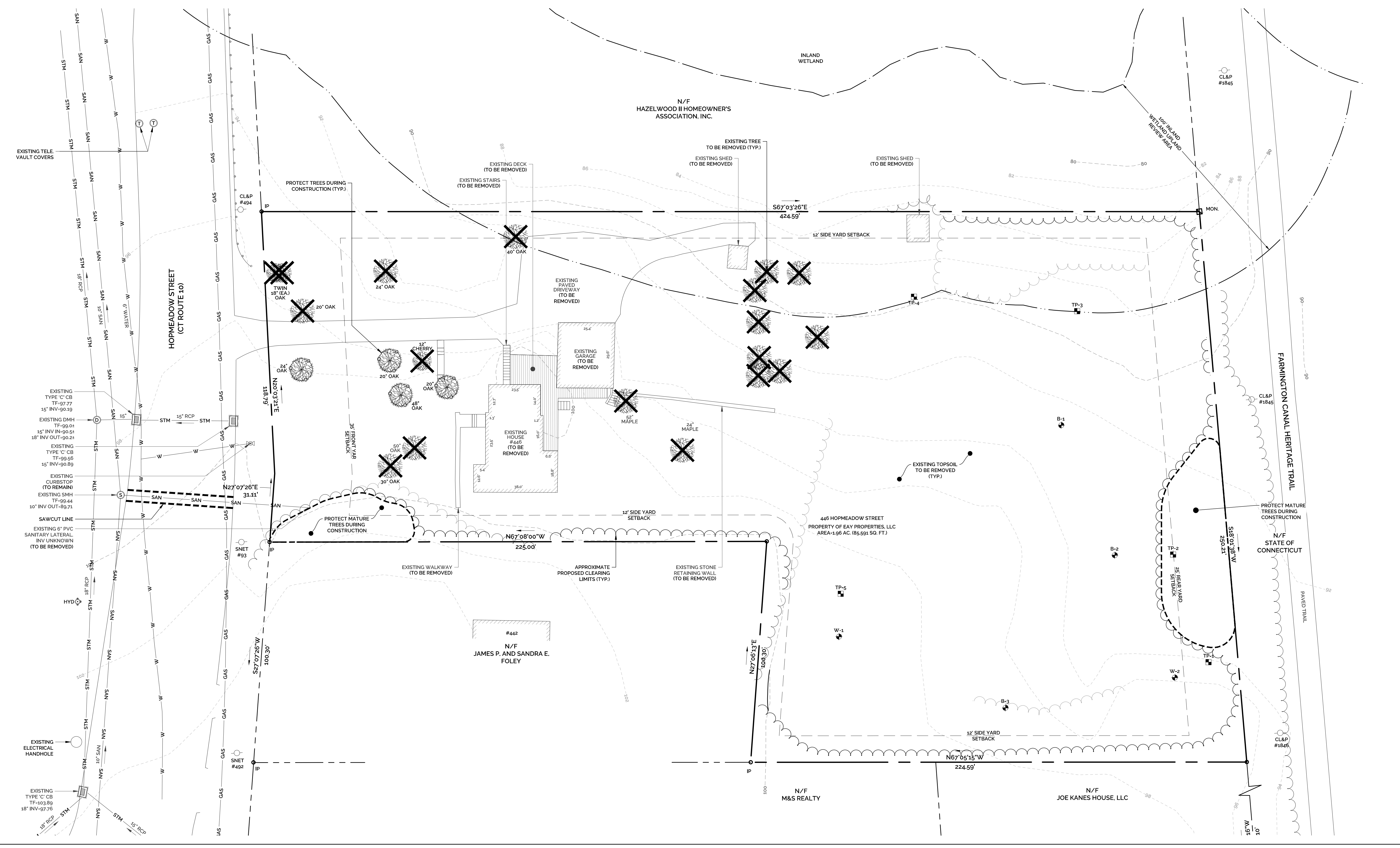

EXISTING CONDITIONS & DEMOLITION PLAN
VESSEL MULTI-FAMILY HOUSING
PROPERTY ADDRESS
446 HOPMEADOW STREET, SIMSBURY, CT 06089
PREPARED FOR
VESSEL RE HOLDINGS, LLC
46 WEST 55TH STREET, NEW YORK, NY 10019

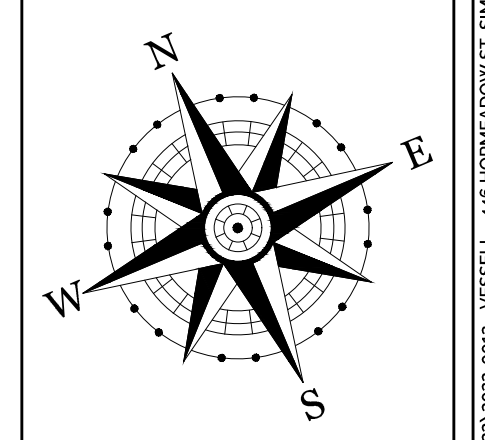

SCALE IN FEET
20 10 0 10 20
1" = 20'

PROJECT NO. 2022-0013	SCALE 1" = 20'
DRAWN BY: SMM	DATE 12/16/2022
CHECKED BY: SMM	DATE 12/16/2022

DRAWING
XD-1
SHEET NUMBER: 1 OF 12

GENERAL NOTES:

- THIS PLAN WAS COMPILED USING THE FOLLOWING REFERENCE INFORMATION:
 - A CLASS A-2 & CLASS T-2 SURVEY MAP ENTITLED, "PROPERTY SURVEY, PREPARED FOR VESSEL TECHNOLOGIES INC., 446 HOPMEADOW STREET, SIMSBURY, CONNECTICUT," SCALE: 1"=30', DATED: NOVEMBER 9, 2022, PREPARED BY ROB HELLSTROM LAND SURVEYING LLC
 - A MAP ENTITLED, "TOWN OF SIMSBURY, CONNECTICUT TOWN ACAD WETLAND MAP 2014, MAP G13," SCALE: 1"=100', PREPARED BY NEW ENGLAND GEOSYSTEMS.
- THE APPLICANT IS VESSEL TECHNOLOGIES INC. OF 46 WEST 55TH STREET, NEW YORK, NY 10019. THE PROPERTY OWNER IS EAY PROPERTIES LLC OF 540 HOPMEADOW STREET #6, SIMSBURY, CT 06097.
- THE SUBJECT PARCEL IS IDENTIFIED AS LOT 00C3 ON TAX ASSESSORS MAP G13, BLOCK 142. THE DEED REFERENCE OF THE PROPERTY IS VOLUME 882 PAGE 222. THE AREA OF THE PARCEL IS 85,591 SQ. FT. (1.961 ACRES).
- THE SUBJECT PROPERTY IS LOCATED IN THE HIGH DENSITY RESIDENTIAL 'R-15' ZONING DISTRICT.
- THE EXISTING PARCEL IS DEVELOPED AS A SINGLE-FAMILY RESIDENCE. THE APPLICANT IS PROPOSING TO DEMOLISH THE EXISTING BUILDING AND IMPROVEMENTS AND CONSTRUCT A NEW FOUR-STORY, 14,063 SQ. FT. MULTI-FAMILY RESIDENTIAL BUILDING, CONSISTING OF 77 ONE-BEDROOM UNITS AND 3 TWO-BEDROOM UNITS FOR A TOTAL OF 80 UNITS. SITE IMPROVEMENTS WILL INCLUDE A NEW TWO-WAY ACCESS DRIVE FROM HOPMEADOW ROAD (CT ROUTE 10). A NEW 95 VEHICLE PARKING LOT, NEW UTILITY CONNECTIONS, NEW LANDSCAPING IMPROVEMENTS, AND A NEW STORMWATER MANAGEMENT SYSTEM. THE DEVELOPMENT IS BEING PROPOSED IN ACCORDANCE WITH GENERAL STATUTES 8-30G.
- THE PURPOSE OF THESE PLANS IS FOR REVIEW BY THE TOWN OF SIMSBURY INLAND WETLANDS & WATERCOURSES COMMISSION FOR A WETLANDS PERMIT, THE TOWN OF SIMSBURY PLANNING & ZONING COMMISSION FOR A SITE PLAN APPLICATION, AND THE CONNECTICUT DEPARTMENT OF TRANSPORTATION FOR WORK WITHIN THE CT ROUTE 10 RIGHT-OF-WAY. THESE PLANS ARE FOR PERMIT PURPOSES ONLY AND ARE NOT TO BE USED FOR CONTRACT DOCUMENTS.
- REFER TO ARCHITECTURAL DRAWINGS FOR PROPOSED BUILDING INFORMATION.

SITE NOTES:

- ALL SITE LIGHTING SHALL BE FULL CUT OFF FIXTURES AND ARRANGED TO MINIMIZE GLARE BEYOND PROPERTY BOUNDARY AND SHALL PROVIDE ADEQUATE GROUND LEVEL ILLUMINATION FOR SAFE VEHICULAR AND PEDESTRIAN CIRCULATION.
- ALL WORK TO CONFORM TO THE TOWN OF SIMSBURY, CT CONSTRUCTION STANDARDS.
- ALL TRAFFIC CONTROL SIGNS AND PAVEMENT MARKINGS SHALL BE INSTALLED IN THE LOCATIONS SHOWN AND IN ACCORDANCE WITH THE MANUAL FOR UNIFORM TRAFFIC CONTROL DEVICES (M.U.T.C.D.). ALL PARKING LOT STRIPING (EXCEPT FIRE LANE MARKINGS) SHALL BE INSTALLED WITH DURABLE WHITE PAVEMENT MARKING PAINT. THE HANDICAP PARKING SYMBOLS SHALL BE WHITE WITH STANDARD HANDICAP BLUE BACKGROUNDS.
- FIRE LANES SHALL BE INSTALLED AND MAINTAINED IN ACCORDANCE WITH TOWN OF SIMSBURY FIRE DEPARTMENT.
- ALL DISTURBED AREAS NOT COVERED BY BUILDINGS, ASPHALT, STONE SURFACE OR WALKS SHALL BE LANDSCAPED OR GRASSED. GRASSED AREAS SHALL BE LOAMED (4" MIN) FERTILIZED, SEEDED AND MULCHED AS REQUIRED TO SUIT SOIL CONDITIONS.
- ANY AND ALL SIGNAGE SHALL BE REVIEWED AND APPROVED BY THE TOWN PLANNER/ZONING OFFICIAL AND/OR PLANNING & ZONING COMMISSION PRIOR TO INSTALLATION. NO UNAPPROVED SIGNAGE SHALL BE PLACED ON LIGHT POLES, BUILDINGS, OR GROUNDS SUBJECT TO THIS APPROVAL.
- TRASH COLLECTION SHALL BE LIMITED TO 7:00 A.M. TO 6:00 P.M. MONDAY THROUGH FRIDAY.
- HOURS OF CONSTRUCTION SHALL BE LIMITED TO 7:00 A.M. TO 6:00 P.M. MONDAY THROUGH FRIDAY, AND 8:00 A.M. TO 6:00 P.M. SATURDAY. NO CONSTRUCTION ACTIVITY SHALL TAKE PLACE ON SUNDAYS. ADDITIONALLY, NO EXTERIOR LIGHTING FOR CONSTRUCTION PURPOSES, FREESTANDING OR OTHERWISE, IS APPROVED WITH THIS APPLICATION.
- DELIVERIES OF MATERIALS/EQUIPMENT TO THE SITE RELATED TO THIS CONSTRUCTION PROJECT ARE LIMITED TO 7:00 A.M. TO 5:00 P.M. MONDAY TO SATURDAY.
- PRIOR TO ISSUANCE OF A CERTIFICATE OF OCCUPANCY, AN AS-BUILT DRAWING SHALL BE SUBMITTED FOR THE FILE.
- SNOW STORAGE AREAS ARE INDICATED ON THE PLAN. DURING LARGE STORM EVENTS, UP TO 12 TOTAL PARKING SPACES MAY BE USED FOR SNOW STORAGE (7 SHOWN). HOWEVER, AT NO POINT SHALL THE MINIMUM NUMBER OF AVAILABLE PARKING SPACES BE REDUCED TO LESS THAN THE MINIMUM REQUIRED 83 PARKING SPACES (SEE ZONING NOTE #2).
- IN THE EVENT THAT SURPLUS SNOW CANNOT BE STORED ON SITE IN THE DESIGNATED AREAS, THE SURPLUS SNOW SHALL BE REMOVED FROM THE SITE AND STOCKPILED AT AN APPROVED LOCATION IN ACCORDANCE WITH ANY AND ALL APPLICABLE LAWS AND REGULATIONS. ANY PLANTINGS DAMAGED DURING ON-SITE SNOW STOCKPILING SHALL BE REPLACED IN KIND. REFER TO SNOW STORAGE TABLE BELOW FOR STORAGE DEPTH CALCULATIONS.

GENERAL CONSTRUCTION NOTES:

- THE CONTRACTOR SHALL CONTACT "CALL BEFORE YOU DIG" AT 800-922-4455 TO MARK OUT ALL UNDERGROUND UTILITIES A MINIMUM OF 3 BUSINESS DAYS PRIOR TO COMMENCING ANY CONSTRUCTION ACTIVITY. CONTRACTOR SHALL VERIFY ALL LOCATIONS, DIMENSIONS AND ELEVATIONS OF ALL UTILITIES PRIOR TO CONSTRUCTION. IF UTILITIES DIFFER FROM THOSE SHOWN ON THIS PLAN, ENGINEER SHALL BE NOTIFIED.
- ALL PROPERTY LINES SHALL BE VERIFIED IN THE FIELD. NO PRIVATE PROPERTY SHALL BE DISTURBED UNLESS PROPER RIGHTS ARE OBTAINED PRIOR TO CONSTRUCTION.
- THE CONTRACTOR SHALL OBTAIN ALL REQUIRED PERMITS PRIOR TO CONSTRUCTION.
- THE CONTRACTOR SHALL OBTAIN, REVIEW AND ADHERE TO ALL REQUIREMENTS AND ANY CONDITIONS OF APPROVAL OF THE TOWN OF SIMSBURY.
- EXISTING DRAINAGE PATTERNS SHALL BE SUBSTANTIALLY MAINTAINED. THE CONTRACTOR SHALL GRADE THE PROPERTY IN SUCH A MANNER TO MAINTAIN EXISTING LOCAL DRAINAGE PATTERNS AND TO PREVENT EXCESS RUNOFF AND/OR PONDING ON ADJACENT PROPERTIES BOTH DURING AND AFTER CONSTRUCTION.
- A CONNECTICUT DEPARTMENT OF TRANSPORTATION HIGHWAY ENCROACHMENT PERMIT IS REQUIRED FOR ALL IMPROVEMENTS, INCLUDING BUT NOT LIMITED TO APRONS, CURB CUTS, UTILITY LATERALS AND ROADWAY PAVEMENT PATCHING, WITHIN THE STATE RIGHT-OF-WAY.

SNOW STORAGE TABLE			
SNOWFALL DEPTH (INCHES)	"IN PLACE" SNOW VOLUME (CUBIC FEET)	50% COMPACTED SNOW VOLUME (CUBIC FEET)	STORAGE DEPTH (INCHES/FEET)
1	2,852	1,426	(3.3 / 0.28)
3	8,555	4,278	(10.0 / 0.83)
6	17,111	8,556	(19.9 / 1.66)
9	25,666	12,833	(29.9 / 2.49)
12	34,221	17,111	(39.8 / 3.32)
18	51,332	25,666	(59.7 / 4.98)

- NOTES:
- SNOW REMOVAL AREA (PARKING LOT) - 34,221 SQ. FT.
 - SNOW STORAGE AREAS - 2,190 SQ. FT. - 2275 SQ. FT. - 690 SQ. FT. - 5,155 SQ. FT.

ZONING NOTES:

- PER SECTION 17.4 OF THE SIMSBURY ZONING REGULATIONS, MAXIMUM BUILDING HEIGHT IS MEASURED FROM THE AVERAGE FINISHED GRADE AT THE PERIMETER OF THE BUILDING TO THE HIGHEST POINT OF THE BUILDING.
 - THE ELEVATION OF THE AVERAGE FINISHED GRADE AT THE PERIMETER OF THE BUILDING IS 94.2'
 - THE ELEVATION OF THE TOP OF THE PARAPET IS 94.0' (ENTRY ELEVATION) + 42.75' (HEIGHT TO TOP OF PARAPET - SEE ARCHITECTURAL PLANS) = 136.75'
 - THEREFORE, THE HEIGHT OF THE BUILDING = 136.75' - 94.2' = 42.55'
- PARKING CALCULATION:
 - PER SECTION 10.2 OF THE SIMSBURY ZONING REGULATIONS, TWO PARKING SPACES SHALL BE PROVIDED FOR EACH DWELLING UNIT. THEREFORE, 80 UNITS X 2 SPACES/UNIT = 160 PARKING SPACES REQUIRED
 - PER CT PUBLIC ACT 21-59, THE MAXIMUM PARKING LIMITATIONS FOR MULTI-FAMILY DEVELOPMENTS ARE 3 PARKING SPACE FOR EACH ONE-BEDROOM UNIT, AND 2 PARKING SPACES FOR EACH TWO-BEDROOM UNIT.
 - ONE-BR UNITS: 77 ONE-BR UNITS X 1 SPACE/UNIT = 77 PARKING SPACES
 - TWO-BR UNITS: 3 TWO-BR UNITS X 2 SPACES/UNIT = 6 PARKING SPACES
 - TOTAL 77 SPACES + 6 SPACES = 83 PARKING SPACES
 - PARKING SPACES PROVIDED: 95 PARKING SPACES
- THE DEVELOPMENT IS BEING PROPOSED IN ACCORDANCE WITH GENERAL STATUTES 8-30G.

ZONING DATA TABLE		
HIGH DENSITY RESIDENTIAL 'R-15' ZONING DISTRICT		
ITEM	REQUIRED	PROVIDED
MIN. LOT AREA	15,000 SQ. FT.	85,591 SQ. FT.
LOT FRONTAGE	100 FT.	149.91 FT.
FRONT YARD SETBACK	35 FT.	294.2 FT.
SIDE YARD SETBACK	12 FT.	80.0 FT. (N) 18.8 FT. (S)
REAR YARD SETBACK	25 FT.	39.9 FT.
MAX. BUILDING HEIGHT (SEE ZONING NOTE #1)	35 FT.	42.55 FT. (SEE ZONING NOTE #4)
IMPERVIOUS COVERAGE	N/A	51,649 SQ. FT.
MIN. REQUIRED PARKING (SEE ZONING NOTE #2)	160 PARKING SPACES	95 PARKING SPACES

H+H+H ENGINEERING ASSOCIATES
 232 Greenmanville Avenue
 Suite 201
 Mystic, CT 06355
 860-980-8008 (C) 413-579-4488 (M)
 www.hh-engineers.com

REV.	DATE	DESCRIPTION OF REVISION
2	3/17/2023	REVISIONS PER ENGINEERING REVIEW COMMENTS & IWA COMMENTS
1	2/24/2023	REVISIONS PER REVIEW COMMENTS
1		REV.

SITE LAYOUT PLAN
VESSEL MULTI-FAMILY HOUSING
 PROPERTY ADDRESS
 446 HOPMEADOW STREET, SIMSBURY, CT 06089
 PREPARED FOR
VESSEL RE HOLDINGS, LLC
 46 WEST 55TH STREET, NEW YORK, NY 10019

SCALE IN FEET
 20 10 0 10 20
 PROJECT NO. 2022-0013 SCALE 1" = 20'
 DRAWN BY: SMM DATE 12/16/2022
 CHECKED BY: SMM DATE 12/16/2022
DRAWING SL-1
 SHEET NUMBER: 2 OF 12

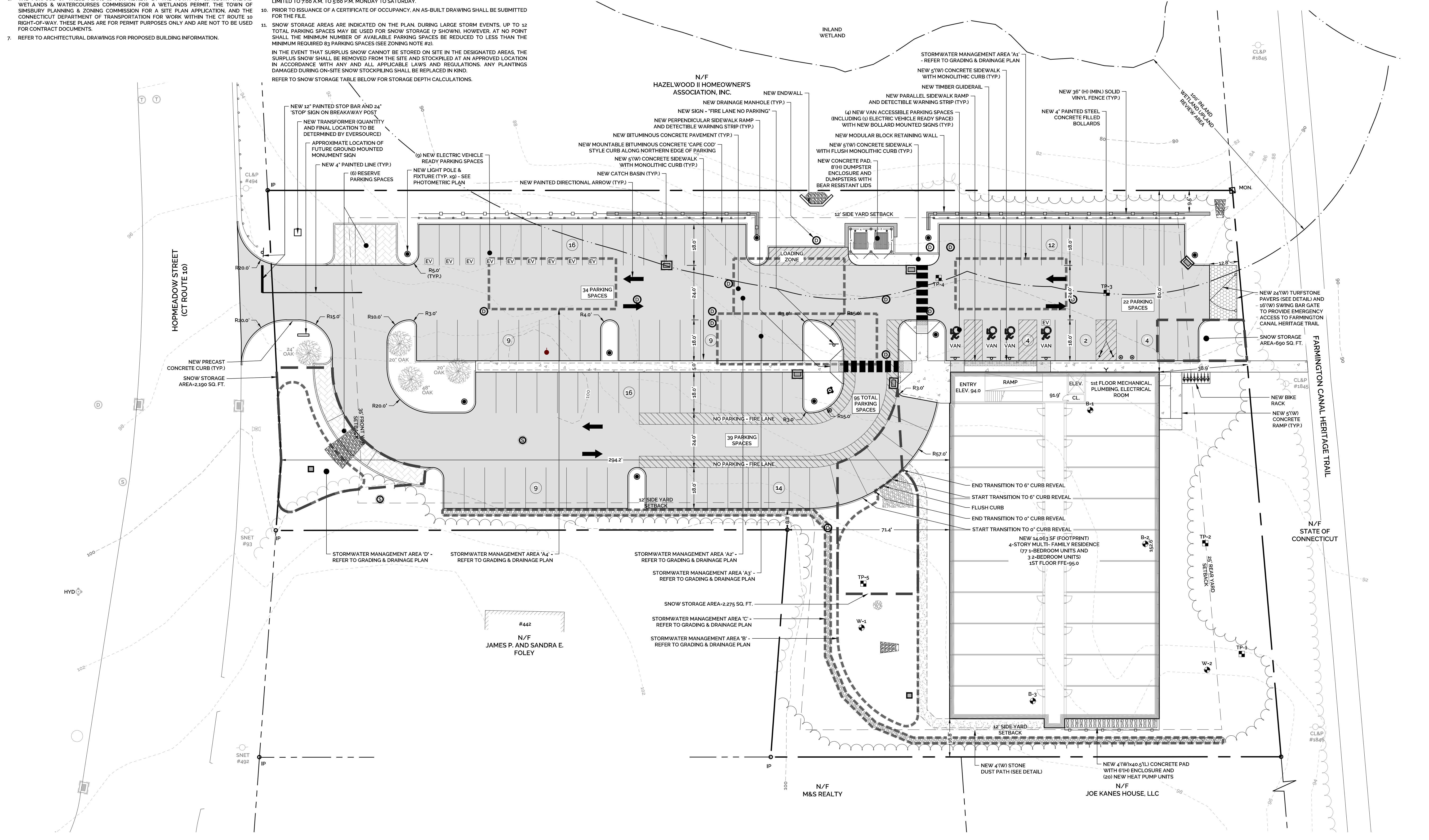

GRADING & DRAINAGE NOTES:

- CONTRACTOR SHALL CLEAN ALL EXISTING AND PROPOSED STRUCTURES AND PIPES UPON COMPLETION OF CONSTRUCTION.
- THE SITE CONTRACTOR SHALL REVIEW THE SITE GRADES AND FEATURES TO ENSURE THAT THE PROPOSED WORK IS CONSISTENT WITH THE EXISTING CONDITIONS AS PRESENTED ON THE PLANS. AT LEAST ONE NEW BENCHMARK WILL NEED TO BE ESTABLISHED ON THE SITE PRIOR TO CONSTRUCTION.
- CONTRACTOR TO VERIFY ALL EXISTING PIPE CONNECTIONS AND INVERTS. ANY CONFLICTS SHOULD BE EXPRESSED TO OWNER AND THE DESIGN ENGINEER.

GENERAL CONSTRUCTION NOTES:

- THE LOCATIONS OF SUBSURFACE UTILITIES SHOWN HEREON ARE APPROXIMATE. THE ACTUAL LOCATION OF SUBSURFACE UTILITIES MAY VARY FROM THOSE INDICATED AND ALL UNDERGROUND UTILITIES MAY NOT BE SHOWN.
- THE CONTRACTOR SHALL CONTACT "CALL BEFORE YOU DIG" AT 800-922-4455 TO MARK OUT ALL UNDERGROUND UTILITIES A MINIMUM OF 3 BUSINESS DAYS PRIOR TO COMMENCING ANY CONSTRUCTION ACTIVITY. CONTRACTOR SHALL VERIFY ALL LOCATIONS, DIMENSIONS AND ELEVATIONS OF ALL UTILITIES PRIOR TO CONSTRUCTION. IF UTILITIES DIFFER FROM THOSE SHOWN ON THIS PLAN, ENGINEER SHALL BE NOTIFIED.
- ALL PROPERTY LINES SHALL BE VERIFIED IN THE FIELD. NO PRIVATE PROPERTY SHALL BE DISTURBED UNLESS PROPER RIGHTS ARE OBTAINED PRIOR TO CONSTRUCTION.
- THE CONTRACTOR SHALL OBTAIN ALL REQUIRED PERMITS PRIOR TO CONSTRUCTION.
- THE CONTRACTOR SHALL OBTAIN, REVIEW AND ADHERE TO ALL REQUIREMENTS AND ANY CONDITIONS OF APPROVAL OF THE TOWN OF SIMSBURY.
- EXISTING DRAINAGE PATTERNS SHALL BE SUBSTANTIALLY MAINTAINED. THE CONTRACTOR SHALL GRADE THE PROPERTY IN SUCH A MANNER TO MAINTAIN EXISTING LOCAL DRAINAGE PATTERNS AND TO PREVENT EXCESS RUNOFF AND/OR PONDING ON ADJACENT PROPERTIES BOTH DURING AND AFTER CONSTRUCTION.
- A CONNECTICUT DEPARTMENT OF TRANSPORTATION HIGHWAY ENCROACHMENT PERMIT IS REQUIRED FOR ALL IMPROVEMENTS, INCLUDING BUT NOT LIMITED TO APRONS, CURB CUTS, UTILITY LATERALS AND ROADWAY PAVEMENT PATCHING, WITHIN THE STATE RIGHT-OF-WAY.

STORMWATER MANAGEMENT SYSTEM MAINTENANCE PLAN:

- GENERAL
 - THE ACCESS DRIVE AND PARKING AREAS SHOULD BE SWEEPED AT LEAST ONCE PER YEAR, PREFERABLY AFTER THE END OF THE WINTER SANDING SEASON.
- CATCH BASINS AND MANHOLES
 - A CONNECTICUT-LICENSED HAULER SHALL PUMP THE SUMPS OF ON-SITE CATCH BASINS AND MANHOLES, AND SHALL DISPOSE OF THE PUMPING LEGALLY. ROAD SAND MAY BE REUSED FOR WINTER SANDING, BUT MAY NOT BE STORED ON-SITE AS PART OF THE HAULING CONTRACT. THE HAULER SHALL NOTIFY THE PROPERTY OWNER IN WRITING WHERE THE MATERIAL IS BEING DISPOSED.
 - EACH CATCH BASIN SHALL BE INSPECTED EVERY FOUR MONTHS, WITH ONE INSPECTION OCCURRING DURING THE MONTH OF APRIL. ANY DEBRIS OCCURRING WITHIN ONE FOOT FROM THE BOTTOM OF EACH SUMP SHALL BE REMOVED BY VACUUM "VACTOR" TYPE OF MAINTENANCE EQUIPMENT.
- STORMTECH UNDERGROUND INFILTRATION SYSTEM
 - THE ISOLATOR ROWS SHALL BE CLEANED AT THE END OF CONSTRUCTION ONCE THE CONTRIBUTING AREAS ARE FULLY STABILIZED FOR THE FIRST YEAR OF OPERATION FOLLOWING CONSTRUCTION. THE CHAMBER ROWS SHALL BE INSPECTED ONCE EVERY 6 MONTHS.
 - AFTER THE FIRST YEAR OF OPERATION, THE CHAMBERS SHALL BE INSPECTED A MINIMUM OF ONCE PER YEAR. IF UPON VISUAL INSPECTION IT IS FOUND THAT SEDIMENT HAS ACCUMULATED, A STADIA ROD SHOULD BE INSERTED TO DETERMINE THE DEPTH OF THE SEDIMENT. WHEN THE AVERAGE DEPTH OF ACCUMULATION EXCEEDS 3", A CLEAN-OUT SHOULD BE PERFORMED AND PROPERLY DISPOSED OFF-SITE. CLEAN-OUT SHOULD BE ACCOMPLISHED USING A JETVAC PROCESS.
 - A DETAILED MAINTENANCE LOGBOOK SHALL BE KEPT ON-SITE FOR THE UNITS BY THE PROPERTY OWNER/MANAGER. INFORMATION IS TO INCLUDE, BUT NOT BE LIMITED TO, THE DATE AND INSPECTION, RECORD OF SEDIMENT DEPTH, GENERAL OBSERVATIONS, AND DATE OF CLEANING PERFORMED.

- BIORETENTION BASIN
 - PRUNE SHRUBS AS NEEDED.
 - BASIN FLOOR AND SLOPES SHALL BE MOWED 6" TO 8" AS NEEDED. GRASS CLIPPINGS, LEAVES AND ACCUMULATED SEDIMENT AND DEBRIS SHALL BE REMOVED DURING THE SUMMER. HOWEVER, PLANT MATTER SHALL BE LEFT IN PLACE OVER WINTER MONTHS TO INSULATE THE SOIL AND ADD ORGANIC MATTER TO THE SOIL. REMOVAL CRITERIA SHALL INCLUDE WHEN PLANT MATTER IS SMOTHERING PLANTS, VEGETATION AND AESTHETICS.
 - REMOVE SEDIMENT GREATER THAN 1.0 INCH DEEP IN MARCH-APRIL IN THE FILTER MEDIA BED IN A MANNER TO MINIMIZE DAMAGE TO VEGETATION.
 - INSPECT SOIL AND REPAIR ERODED AREAS SEASONALLY OR AS NECESSARY.
 - REMOVE ANY INVASIVE SPECIES (INCLUDING ROOTS) THAT HAVE BECOME ESTABLISHED WITHIN THE BASIN AND EMBANKMENTS.
 - IF THERE IS AN ACCUMULATION OF ORGANIC DEBRIS OR SEDIMENT ON THE FLOOR OF THE BASIN, OR IF PONDING WATER IS REGULARLY OBSERVED MORE THAN 48 HOURS AFTER A RAINFALL EVENT, THE TOP 6" SHALL BE REMOVED AND THE EXPOSED SOIL SURFACE ROTOTILLED TO A DEPTH OF 12". SEDIMENTATION SHOULD BE REMOVED WHEN IT IS VISIBLY DRY AND READILY SEPARATES FROM THE BASIN FLOOR TO MINIMIZE SMEARING. AFTER THIS WORK HAS BEEN DONE, THE BOTTOM OF THE BASIN SHALL BE RESTORED TO ITS ORIGINAL CONDITION.
 - NO PESTICIDES OR NON-ORGANIC FERTILIZERS SHALL BE USED IN AREAS DRAINING TO THE BIORETENTION BASIN.
- DRYWELL AND COLLECTION BASIN
 - THE DRYWELL SHALL BE CLEANED AT THE END OF CONSTRUCTION ONCE THE CONTRIBUTING AREAS ARE FULLY STABILIZED. FOR THE FIRST YEAR OF OPERATION FOLLOWING CONSTRUCTION, THE DRYWELLS SHALL BE INSPECTED ONCE EVERY 6 MONTHS.
 - AFTER THE FIRST YEAR OF OPERATION, THE DRYWELLS SHALL BE INSPECTED A MINIMUM OF ONCE PER YEAR. IF UPON VISUAL INSPECTION IT IS FOUND THAT SEDIMENT HAS ACCUMULATED, A STADIA ROD SHOULD BE INSERTED TO DETERMINE THE DEPTH OF THE SEDIMENT. WHEN THE AVERAGE DEPTH OF ACCUMULATION EXCEEDS 3", A CLEAN-OUT SHOULD BE PERFORMED AND PROPERLY DISPOSED OFF-SITE. CLEAN-OUT SHOULD BE ACCOMPLISHED USING A JETVAC PROCESS.
 - COLLECTION BASIN SHALL BE ROUTINELY CHECKED FOR SEDIMENT ACCUMULATION, TRASH AND DEBRIS. BASIN SHALL BE MOWED TO 4-6" AS NEEDED. GRASS CLIPPINGS, LEAVES AND ACCUMULATED SEDIMENT AND DEBRIS SHALL BE REMOVED. REMOVE ANY INVASIVE SPECIES (INCLUDING ROOTS) THAT HAVE BECOME ESTABLISHED WITHIN THE BASIN AND EMBANKMENTS.
 - A DETAILED MAINTENANCE LOGBOOK SHALL BE KEPT ON-SITE FOR THE UNITS BY THE PROPERTY OWNER/MANAGER. INFORMATION IS TO INCLUDE, BUT NOT BE LIMITED TO, THE DATE OF INSPECTION, RECORD OF SEDIMENT DEPTH, GENERAL OBSERVATIONS, AND DATE OF CLEANING PERFORMED.

DRAINAGE STRUCTURE TABLE			
STRUCTURE ID	STRUCTURE TYPE	TOP OF FRAME	INVERT
CB-1	TYPE 'C' CB W/ 4' SUMP AND TRAP HOOD	89.70	86.20 (12" OUT) (W)
ICS-1	INLET CONTROL STRUCTURE	91.35	85.00 (12" IN) (E) 85.86 (12" OUT) (W) 85.86 (12" OUT) (N)
STORMWATER MANAGEMENT AREA 'A2'	ADS STORMTECH MC-3500 SUBSURFACE INFILTRATION SYSTEM	---	85.86 (12" IN) (S) 85.86 (12" OUT)
OCS-1	OUTLET CONTROL STRUCTURE	92.70	85.86 (12" IN) (S) 85.80 (12" OUT) (W)
CB-2	TYPE 'C' CB W/ 4' SUMP AND TRAP HOOD	92.90	87.80 (12" OUT) (S)
ICS-2	INLET CONTROL STRUCTURE	93.30	87.70 (12" IN) (E) 87.66 (12" OUT) (W) 87.66 (12" OUT) (N)
STORMWATER MANAGEMENT AREA 'A2'	ADS STORMTECH MC-3500 SUBSURFACE INFILTRATION SYSTEM	---	87.66 (12" IN) (S) 87.66 (12" OUT)
OCS-2	OUTLET CONTROL STRUCTURE	94.20	87.66 (12" IN) (N & E) 87.60 (12" OUT) (S)

DRAINAGE STRUCTURE TABLE			
STRUCTURE ID	STRUCTURE TYPE	TOP OF FRAME	INVERT
CB-3	TYPE 'C' CB W/ 2' SUMP	94.40	88.50 (12" IN) (E)
CB-4	TYPE 'C' CB W/ 4' SUMP AND TRAP HOOD	93.25	88.20 (12" IN) (W) 88.20 (12" OUT) (N)
ICS-3	INLET CONTROL STRUCTURE	93.50	88.10 (12" IN) (S) 88.06 (12" OUT) (W) 88.06 (12" OUT) (N)
STORMWATER MANAGEMENT AREA 'A3'	ADS STORMTECH MC-3500 SUBSURFACE INFILTRATION SYSTEM	---	88.06 (12" IN) (S & E) 88.06 (12" OUT) (N)
OCS-3	OUTLET CONTROL STRUCTURE	94.50	88.06 (12" IN) (S & E) 88.00 (12" OUT) (N)
CB-5	TYPE 'C' CB W/ 4' SUMP AND TRAP HOOD	94.50	89.00 (12" OUT) (S)
ICS-4	INLET CONTROL STRUCTURE	95.00	88.90 (12" IN) (E) 88.86 (12" OUT) (W) 88.86 (12" OUT) (N)
STORMWATER MANAGEMENT AREA 'A4'	ADS STORMTECH MC-3500 SUBSURFACE INFILTRATION SYSTEM	---	88.86 (12" IN) (S) 88.86 (12" OUT)
OCS-4	OUTLET CONTROL STRUCTURE	95.25	88.86 (12" IN) (N) 88.80 (12" OUT) (E)

DRAINAGE STRUCTURE TABLE			
STRUCTURE ID	STRUCTURE TYPE	TOP OF FRAME	INVERT
DMH-1	DRAINAGE MANHOLE	94.45	87.90 (12" IN) (S) 87.50 (12" IN) (W) 86.90 (12" IN) (W) 86.65 (12" OUT) (E)
DMH-2	DRAINAGE MANHOLE	93.10	85.45 (8" IN) (S) 84.85 (15" IN) (W) 84.85 (15" OUT) (N)
DMH-3	DRAINAGE MANHOLE	93.30	85.70 (12" IN) (E) 84.70 (15" IN) (E) 84.45 (18" OUT) (W)
DMH-4	DRAINAGE MANHOLE	92.50	84.20 (18" IN) (E) 84.20 (18" OUT) (N)
EW-1	CONCRETE ENDWALL	87.00 (TW)	84.10 (18")
OCS-5	OUTLET CONTROL STRUCTURE	93.60	89.00 (12" OUT) (S)
FES-1	FLARED END SECTION	---	87.00 (12")
STORMWATER MANAGEMENT AREA 'C'	CURTAIN DRAIN/ GROUNDWATER DRAIN	---	88.30 (W END IN) 88.65 (E END IN) 87.40 (OUT)
OCS-6	OUTLET CONTROL STRUCTURE	96.50	87.40 (6" IN) (N & S) 87.20 (6" OUT) (E)

DRAINAGE PIPE TABLE				
STRUCTURES	LENGTH (FT)	MATERIAL	PIPE SIZE	SLOPE (FT/FT)
CB-1 - ICS-1	50	CLASS IV RCP	12"	S=0.006
SWM-A1 OUTLET MANIFOLD - OCS-1	15	CORRUGATED HDPE SMOOTH INTERIOR	12"	S=0.000
OCS-1 - DMH-3	6	CORRUGATED HDPE SMOOTH INTERIOR	12"	S=0.017
CB-2 - ICS-2	14	CORRUGATED HDPE SMOOTH INTERIOR	12"	S=0.007
SWM-A2 OUTLET MANIFOLD - OCS-2	6	CORRUGATED HDPE SMOOTH INTERIOR	12"	S=0.000
OCS-2 - DMH-1	9	CORRUGATED HDPE SMOOTH INTERIOR	12"	S=0.011
CB-3 - CB-4	38	CORRUGATED HDPE SMOOTH INTERIOR	12"	S=0.008
CB-4 - ICS-3	9	CORRUGATED HDPE SMOOTH INTERIOR	12"	S=0.011
SWM-A3 OUTLET MANIFOLD - OCS-3	6	CORRUGATED HDPE SMOOTH INTERIOR	12"	S=0.000
OCS-3 - DMH-1	2	CORRUGATED HDPE SMOOTH INTERIOR	12"	S=0.050
CB-5 - ICS-4	17	CORRUGATED HDPE SMOOTH INTERIOR	12"	S=0.006
SWM-A4 OUTLET MANIFOLD - OCS-4	18	CORRUGATED HDPE SMOOTH INTERIOR	12"	S=0.000
OCS-4 - DMH-1	98	CORRUGATED HDPE SMOOTH INTERIOR	12"	S=0.019
DMH-1 - DMH-2	93	CORRUGATED HDPE SMOOTH INTERIOR	15"	S=0.019
DMH-2 - DMH-3	25	CORRUGATED HDPE SMOOTH INTERIOR	15"	S=0.006
DMH-3 - DMH-4	47	CORRUGATED HDPE SMOOTH INTERIOR	18"	S=0.005
DMH-4 - EW-1	15	CORRUGATED HDPE SMOOTH INTERIOR	18"	S=0.007
OCS-5 - FES-1	361	CORRUGATED HDPE SMOOTH INTERIOR	12"	S=0.006
SWM-C PERF. PIPE (W)	171	SDR-35 PVC PERFORATED PIPE	6"	S=0.005
SWM-C PERF. PIPE (E)	247	SDR-35 PVC PERFORATED PIPE	6"	S=0.005
OCS-6 - DMH-2	110	CORRUGATED HDPE SMOOTH INTERIOR	8"	S=0.016

H+H ENGINEERING ASSOCIATES
 232 Greenmanville Avenue Suite 201
 Mystic, CT 06355
 860-980-8008 (C) 413-579-4488 (M)
 www.hh-engineers.com

REV	DATE	DESCRIPTION	BY	CHK
2	3/17/2023	REVISIONS PER ENGINEERING REVIEW COMMENTS & IWA COMMENTS	SHM	SHM
1	2/24/2023	REVISIONS PER REVIEW COMMENTS	SHM	SHM

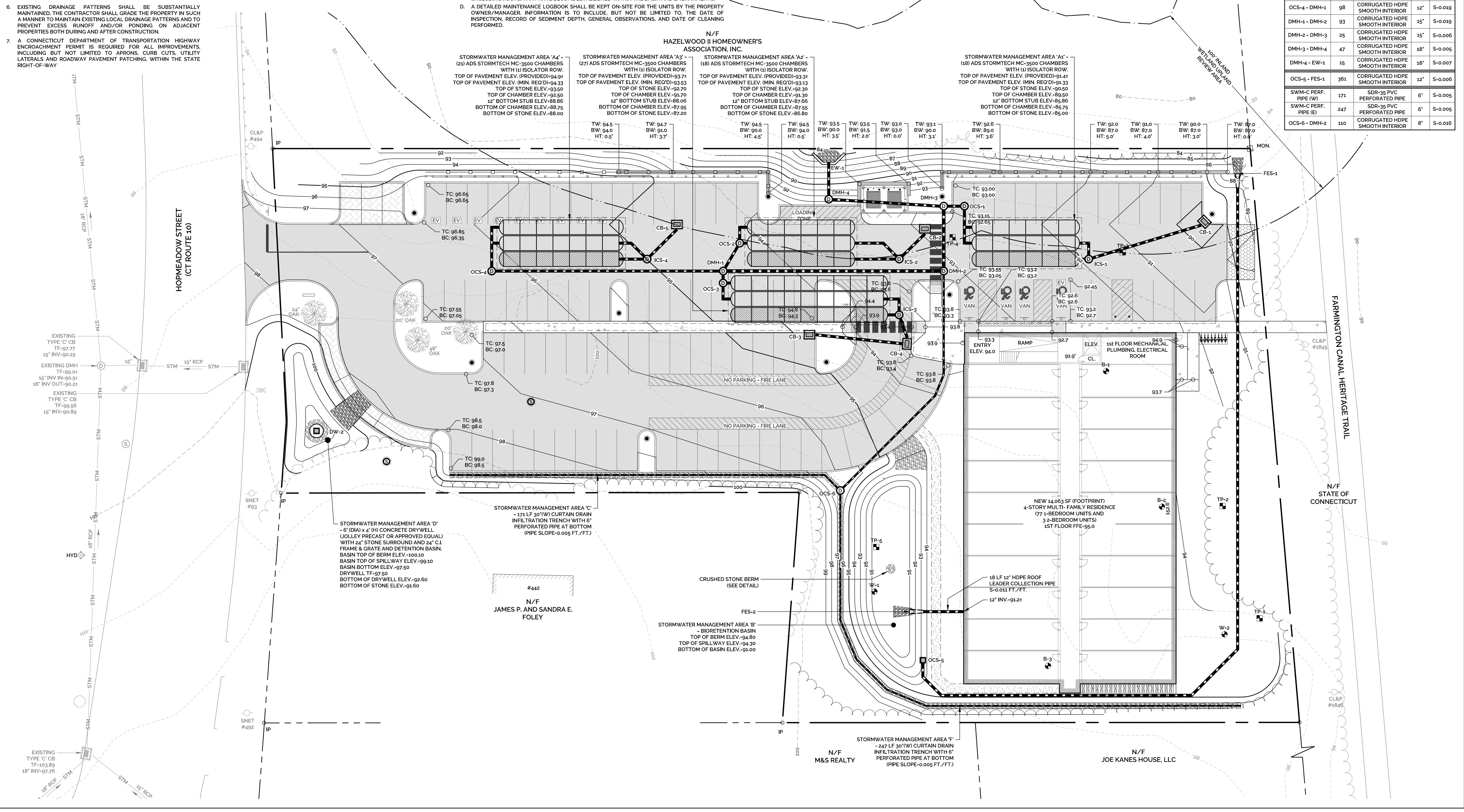

GRADING & DRAINAGE PLAN
VESSEL MULTI-FAMILY HOUSING
 PROPERTY ADDRESS: 446 HOPMEADOW STREET, SIMSBURY, CT 06089
 PREPARED FOR: VESSEL RE HOLDINGS, LLC
 46 WEST 55TH STREET, NEW YORK, NY 10019

SCALE IN FEET
 1" = 20'

PROJECT NO: 2022-0013
 SCALE: 1" = 20'
 DRAWN BY: SHM
 DATE: 12/16/2022
 CHECKED BY: SHM
 DATE: 12/16/2022

DRAWING: GD-1
 SHEET NUMBER: 3 OF 12

UTILITY NOTES:

- ALL NEW UTILITIES, INCLUDING CATV, WILL BE LOCATED UNDERGROUND.
- ALL UTILITY WORK TO CONFORM TO TOWN OF SIMSBURY STANDARDS AND POLICIES AND PRACTICES OF THE DEPARTMENT OF PUBLIC WORKS.
- ELECTRIC, TELEPHONE, CABLE, WATER, AND SANITARY SEWER SERVICES SHALL CONFORM TO THE POLICIES AND PRACTICES OF THE APPROPRIATE UTILITY AUTHORITY. ELECTRICAL SERVICES ARE PROVIDED BY EVERSOURCE. WATER SERVICES ARE PROVIDED BY AQUARIAN WATER COMPANY. SANITARY SEWER SERVICES ARE PROVIDED BY THE TOWN OF SIMSBURY.
- ALL UTILITIES AND ON-SITE STORM DRAINAGE SHALL BE STRUCTURALLY SUPPORTED TO MINIMIZE DISRUPTION FROM SETTLEMENT OF UNDERLYING SOIL.
- SANITARY SEWER SERVICES SHALL BE SDR35 PVC PIPE. SEWER MANHOLES SHALL BE 5' DIA. PRECAST CONCRETE WITH HEAVY DUTY CAST IRON GRATES.
- UTILITY SERVICE SIZES, MATERIALS, AND INSTALLATIONS SHALL BE APPROVED AND INSPECTED BY THE APPROPRIATE UTILITY COMPANY.
- LIGHTING SHALL BE DIRECTED INTERNALLY TOWARDS PARKING AREAS. LIGHT STANDARDS, LUMINAIRES, WIRING & LOCATION SHALL BE DESIGNED BY A LICENSED ELECTRICAL ENGINEER.
- PROVIDE MINIMUM VERTICAL SEPARATION OF 12" FROM WATER MAIN TO DRAINAGE PIPING AND 18" TO SANITARY SEWER PIPING.
- LOCATION AND SIZE OF ALL BUILDING UTILITY CONNECTIONS SHALL BE COORDINATED WITH BUILDING ARCHITECTURAL PLANS AND APPROPRIATE UTILITY AUTHORITY.

UTILITY NOTES CONTINUED:

- WATER SERVICE INSTALLATION NOTES:
 - ALL WATER MAIN AND SERVICE INSTALLATIONS SHALL CONFORM TO THE POLICIES AND PRACTICES OF THE TOWN OF SIMSBURY DEPARTMENT OF PUBLIC WORKS AND ENGINEERING DIVISION.
 - APPROVED BACKFLOW PREVENTERS ARE REQUIRED ON ALL FIRE SPRINKLER AND DOMESTIC WATER LINES.
 - MINIMUM COVER OVER TOP OF WATER MAIN SHALL BE 4'-6" FROM FINISH GRADE.
 - PIPE SEPARATIONS:
 - 10' MINIMUM BETWEEN WATER AND SANITARY SEWER
 - 10' MINIMUM BETWEEN WATER AND BUILDINGS
 - 5' MINIMUM BETWEEN WATER AND CATCH BASINS OR DRAIN PIPES
 - SITE MUST BE AT SUBGRADE BEFORE WATER UTILITIES CAN BE INSTALLED.
 - ARCHITECTURAL PLANS SHALL SHOW UTILITY ROOM, ENTRY POINT OF WATER SERVICE, AND METER LOCATIONS.
 - ALL BRANCH LINE VALVES TO BE LOCATED AS CLOSE AS POSSIBLE TO MAIN LINES.
- MINIMUM 6" SEPARATION BETWEEN ELECTRIC AND ALL OTHER PIPES SUCH AS WATER, SEWER AND DRAINS. ALL ELECTRIC FACILITIES SUCH AS CONDUITS AND PRIMARY & SECONDARY HANDHOLES SHALL CONFORM TO THE REQUIREMENTS OF EVERSOURCE.
- SANITARY SEWER INSTALLATION NOTES:
 - ALL ABANDONED PIES MUST BE TAKEN OUT AND REMOVED FROM THE JOB SITE. EXISTING SANITARY SEWER PIPES MAY NOT BE RE-USED ON SITE.
 - ANY CORED OPENINGS IN MANHOLES NOT BEING USED MUST BE PLUGGED.

GENERAL CONSTRUCTION NOTES:

- THE LOCATIONS OF SUBSURFACE UTILITIES SHOWN HEREON ARE APPROXIMATE. THE ACTUAL LOCATION OF SUBSURFACE UTILITIES MAY VARY FROM THOSE INDICATED AND ALL UNDERGROUND UTILITIES MAY NOT BE SHOWN.
- THE CONTRACTOR SHALL CONTACT "CALL BEFORE YOU DIG" AT 800-922-4455 TO MARK OUT ALL UNDERGROUND UTILITIES A MINIMUM OF 3 BUSINESS DAYS PRIOR TO COMMENCING ANY CONSTRUCTION ACTIVITY. CONTRACTOR SHALL VERIFY ALL LOCATIONS, DIMENSIONS AND ELEVATIONS OF ALL UTILITIES PRIOR TO CONSTRUCTION. IF UTILITIES DIFFER FROM THOSE SHOWN ON THIS PLAN, ENGINEER SHALL BE NOTIFIED.
- ALL PROPERTY LINES SHALL BE VERIFIED IN THE FIELD. NO PRIVATE PROPERTY SHALL BE DISTURBED UNLESS PROPER RIGHTS ARE OBTAINED PRIOR TO CONSTRUCTION.
- THE CONTRACTOR SHALL OBTAIN ALL REQUIRED PERMITS PRIOR TO CONSTRUCTION.
- THE CONTRACTOR SHALL OBTAIN, REVIEW AND ADHERE TO ALL REQUIREMENTS AND ANY CONDITIONS OF APPROVAL OF THE TOWN OF SIMSBURY.
- EXISTING DRAINAGE PATTERNS SHALL BE SUBSTANTIALLY MAINTAINED. THE CONTRACTOR SHALL GRADE THE PROPERTY IN SUCH A MANNER TO MAINTAIN EXISTING LOCAL DRAINAGE PATTERNS AND TO PREVENT EXCESS RUNOFF AND/OR PONDING ON ADJACENT PROPERTIES BOTH DURING AND AFTER CONSTRUCTION.
- A CONNECTICUT DEPARTMENT OF TRANSPORTATION HIGHWAY ENCROACHMENT PERMIT IS REQUIRED FOR ALL IMPROVEMENTS, INCLUDING BUT NOT LIMITED TO APRONS, CURB CUTS, UTILITY LATERALS AND ROADWAY PAVEMENT PATCHING, WITHIN THE STATE RIGHT-OF-WAY.

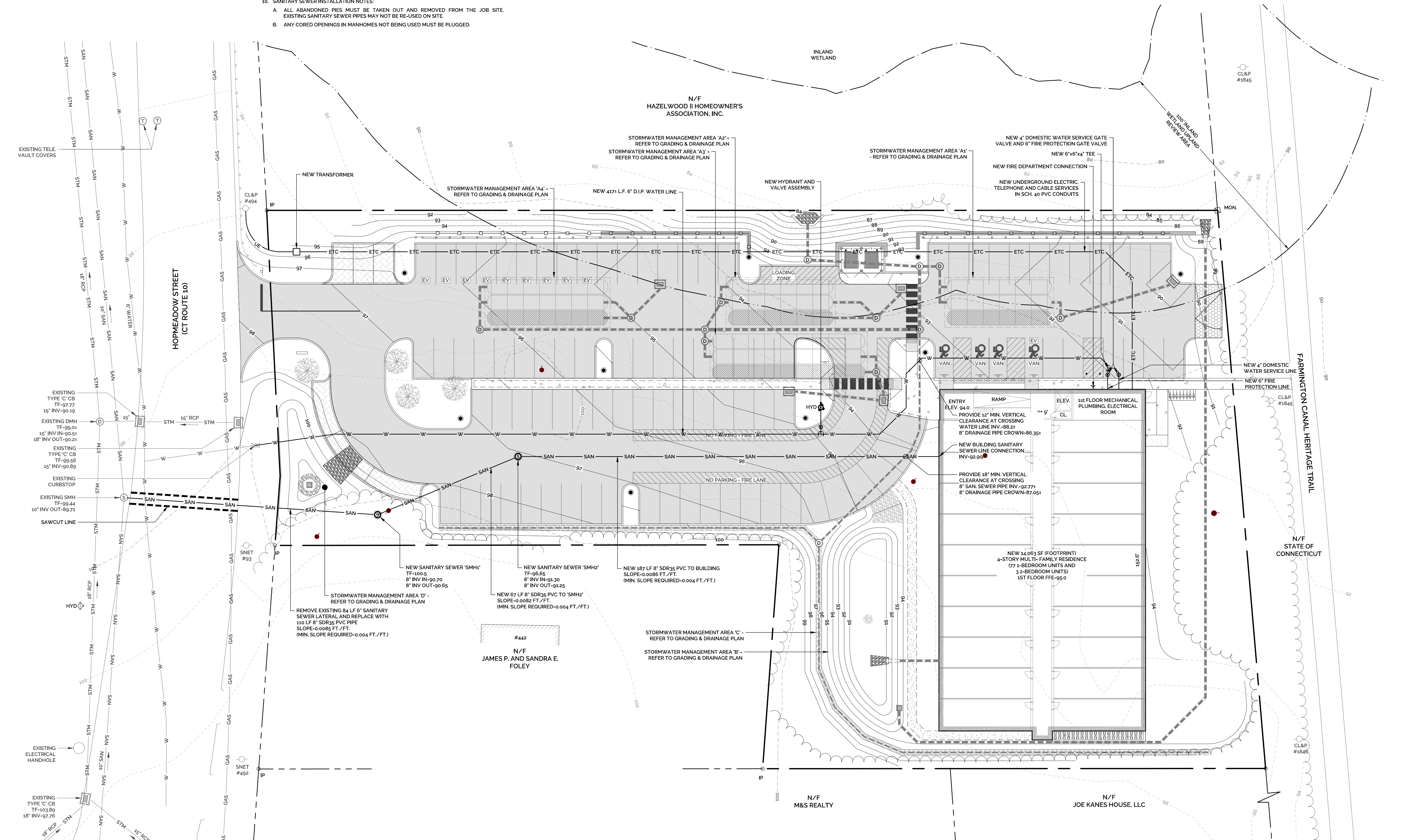

REV	DATE	DESCRIPTION OF REVISION
1	2/24/2023	REVISIONS PER ENGINEERING REVIEW COMMENTS & IWA COMMENTS
2	3/17/2023	REVISIONS PER ENGINEERING REVIEW COMMENTS & IWA COMMENTS

UTILITIES PLAN

VESSEL MULTI-FAMILY HOUSING
 PROPERTY ADDRESS
 446 HOPMEADOW STREET, SIMSBURY, CT 06089
 PREPARED FOR
VESSEL RE HOLDINGS, LLC
 46 WEST 55TH STREET, NEW YORK, NY 10019

CL&P #1845

CL&P #1845

CL&P #1845

SCALE IN FEET
 20 10 0 10 20
 1" = 20'

PROJECT NO. 2022-0013	SCALE 1" = 20'
DRAWN BY: SMM	DATE 12/16/2022
CHECKED BY: SMM	DATE 12/16/2022

DRAWING UT-1

SHEET NUMBER: 4 OF 12

Z:\SIMSBURY\ENGINEERING ASSOCIATES\PROJECTS\2022\2022-0013 - VESSEL - 446 HOPMEADOW ST. SIMSBURY\DWGS\04-UTILITIES.DWG User: UTILITIES Saved: 3/17/2023 3:48 PM Perisce 3/17/2023 3:48 PM

SOIL EROSION & SEDIMENT CONTROL NOTES:

1. THE CONTRACTOR SHALL TAKE ALL NECESSARY MEASURES TO PROTECT ADJACENT PROPERTIES FROM ANY EROSION AND/OR SEDIMENTATION. REFER TO SOIL EROSION & SEDIMENT CONTROL PLAN AND NARRATIVE FOR PROPOSED SOIL EROSION & SEDIMENT CONTROL MEASURES.
2. REFER TO THE SOIL EROSION & SEDIMENT CONTROL NARRATIVE FOR ADDITIONAL INFORMATION.

GENERAL CONSTRUCTION NOTES:

1. THE LOCATIONS OF SUBSURFACE UTILITIES SHOWN HEREON ARE APPROXIMATE. THE ACTUAL LOCATION OF SUBSURFACE UTILITIES MAY VARY FROM THOSE INDICATED AND ALL UNDERGROUND UTILITIES MAY NOT BE SHOWN.
2. THE CONTRACTOR SHALL CONTACT "CALL BEFORE YOU DIG" AT 800-922-4455 TO MARK OUT ALL UNDERGROUND UTILITIES A MINIMUM OF 3 BUSINESS DAYS PRIOR TO COMMENCING ANY CONSTRUCTION ACTIVITY. CONTRACTOR SHALL VERIFY ALL LOCATIONS, DIMENSIONS AND ELEVATIONS OF ALL UTILITIES PRIOR TO CONSTRUCTION. IF UTILITIES DIFFER FROM THOSE SHOWN ON THIS PLAN, ENGINEER SHALL BE NOTIFIED.
3. ALL PROPERTY LINES SHALL BE VERIFIED IN THE FIELD. NO PRIVATE PROPERTY SHALL BE DISTURBED UNLESS PROPER RIGHTS ARE OBTAINED PRIOR TO CONSTRUCTION.
4. THE CONTRACTOR SHALL OBTAIN ALL REQUIRED PERMITS PRIOR TO CONSTRUCTION.
5. THE CONTRACTOR SHALL OBTAIN, REVIEW AND ADHERE TO ALL REQUIREMENTS AND ANY CONDITIONS OF APPROVAL OF THE TOWN OF SIMSBURY.
6. EXISTING DRAINAGE PATTERNS SHALL BE SUBSTANTIALLY MAINTAINED. THE CONTRACTOR SHALL GRADE THE PROPERTY IN SUCH A MANNER TO MAINTAIN EXISTING LOCAL DRAINAGE PATTERNS AND TO PREVENT EXCESS RUNOFF AND/OR PONDING ON ADJACENT PROPERTIES BOTH DURING AND AFTER CONSTRUCTION.
7. A CONNECTICUT DEPARTMENT OF TRANSPORTATION HIGHWAY ENCROACHMENT PERMIT IS REQUIRED FOR ALL IMPROVEMENTS, INCLUDING BUT NOT LIMITED TO APRONS, CURB CUTS, UTILITY LATERALS AND ROADWAY PAVEMENT PATCHING, WITHIN THE STATE RIGHT-OF-WAY.

STAMP

REV	DATE	DESCRIPTION OF REVISION	SHM	SHM
2	3/17/2023	REVISIONS PER ENGINEERING REVIEW COMMENTS & IWA COMMENTS	SHM	SHM
1	2/24/2023	REVISIONS PER REVIEW COMMENTS	SHM	SHM

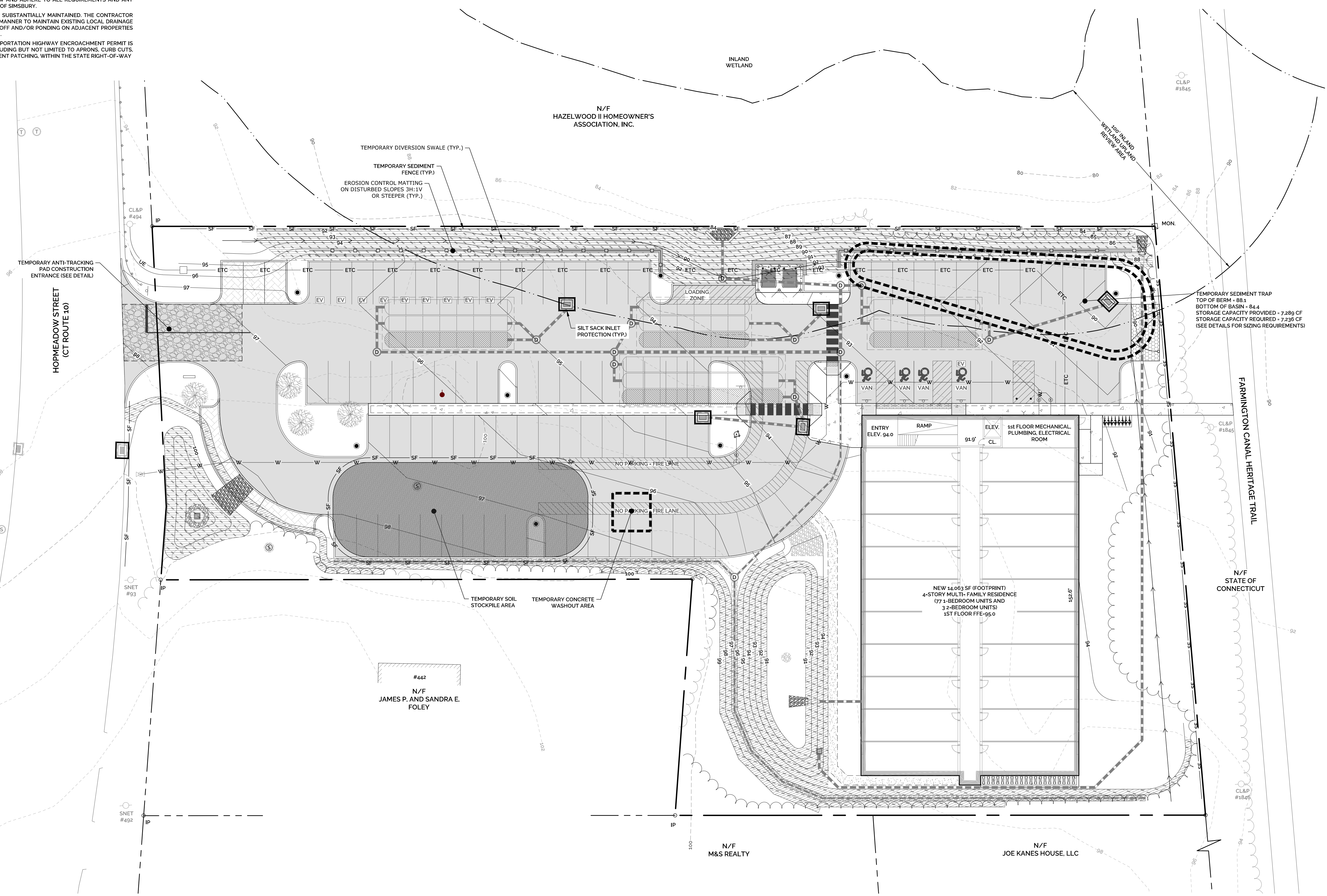

SOIL EROSION & SEDIMENT CONTROL PLAN
VESSEL MULTI-FAMILY HOUSING
PROPERTY ADDRESS
446 HOPMEADOW STREET, SIMSBURY, CT 06089
PREPARED FOR
VESSEL RE HOLDINGS, LLC
46 WEST 55TH STREET, NEW YORK, NY 10019

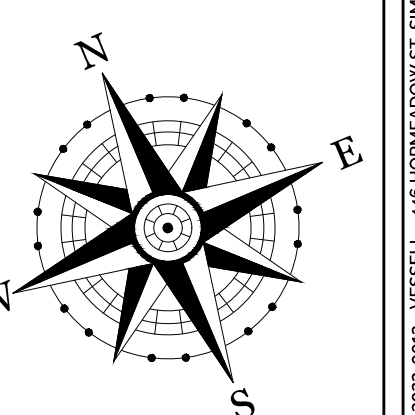

SCALE IN FEET
20 10 0 10 20
1" = 20'

PROJECT NO. 2022-0013	SCALE 1" = 20'
DRAWN BY: SMM	DATE 12/16/2022
CHECKED BY: SMM	DATE 12/16/2022

DRAWING
SE-1
SHEET NUMBER: 5 OF 12

Z:\SIMSBURY\ENGINEERING ASSOCIATES\PROJECTS\2022\2022-0013 - VESSEL - 446 HOPMEADOW ST SIMSBURY\DWG\05-SECDWG.dwg User: JESSE.Savage 3/17/2023 3:50 PM

MERKUR
SOLAR OUTDOOR

photinus
brilliance in solar lighting

SPECIFICATIONS



Source: LED
Efficiency: 200lm/W
Power: Max 100W
L80 Life: >75,000 hours
Location: Label IP67
Solar Module Performance: Monocrystalline silicon cells, processed by Photinus
 4 solar modules x 150 Vmp, modules also charge in cloudy conditions
Battery: LiFePO4 / 42V, 9Ah (12.8 x 3.37Ah)
Operating Temperature: -20°C to +60°C
Battery Life: Up to 10 years
Protection Class: IP68
Material: Steel pole and aluminum parts
Finish: Galvanized and powder coat
Weight: 242.5 lb. (110kg)
Wind Load: 65.3 mph, 90 mph**
Salt Spray Test: ISO 9227:2012
Warranty: 3 Years

*Vp = Watt Peak: maximum power supplied in standard conditions
 ** Other wind loads available upon request

ORDER CODE

Model	Modules	Head	C.C.T.	Optic	Time Management	Height	Wind Load	Mounting	Finish	Options
MERKUR	150 = 4 Solar Modules 150PLUS = 8 Solar Modules 300 = 8 Solar Modules	S = Single D = Dual	40 = Standard 4000K 20 = 3000K 30 = 3000K 50 = 3000K	ME PLACE T2 = 120° T2-L = 120° T3 = 120° T3-L = 120° T4 = 120° T4-B = 120° SCL DWCSCCL	V5 = Standard Setting V3 = Continuous lighting V4 = Night-time reduction to 40% V6 = Night-time reduction to 5%	HS = Standard Height W68 = Standard 68.3 height HC = Custom** WC = Custom**	W68 = Standard 68.3 height W90 = 90 height WC = Custom**	FF = Pipe Foundation ABO = Anchor Base with Covering** ABC = Anchor Base Closed**	D = Dark Blnk = None PIR = PIR Sensor	+ other time management options upon request, consult factory + specify desired height, consult factory + specify desired windload, consult factory + *ABO/ABC surface mount, available upon request, consult factory

Example order code: MERKUR-300-S-40-DWCSCCL-V5-HS-W90-PF-D
 Merkur-Rev4-2022 +1 803 766 0481 info@photinus-lighting.us photinus-lighting.us 1

Calculation Summary

Label	CalcType	Units	Avg	Max	Min	Avg/Min	Max/Min
Site Calc	Illuminance	Fc	0.99	8.6	0.0	N.A.	N.A.

GENERAL NOTES:
 1. PHOTOMETRIC PLAN PROVIDED BY ILLUMINATE.

Luminaire Schedule

Symbol	Qty	Label	Arrangement	Total Lamp Lumens	LLF	Description
[Symbol]	5	T3	SINGLE	N.A.	0.900	Photinus Merkur-150-S-30-V5-HS-W90-xx-T3B
[Symbol]	1	T4	SINGLE	N.A.	0.900	Photinus Merkur-150-S-30-V5-HS-W90-xx-T4B
[Symbol]	3	T4 DOUBLE	BACK-BACK	N.A.	0.900	Photinus Merkur-150-D-30-V5-HS-W90-xx-T4B

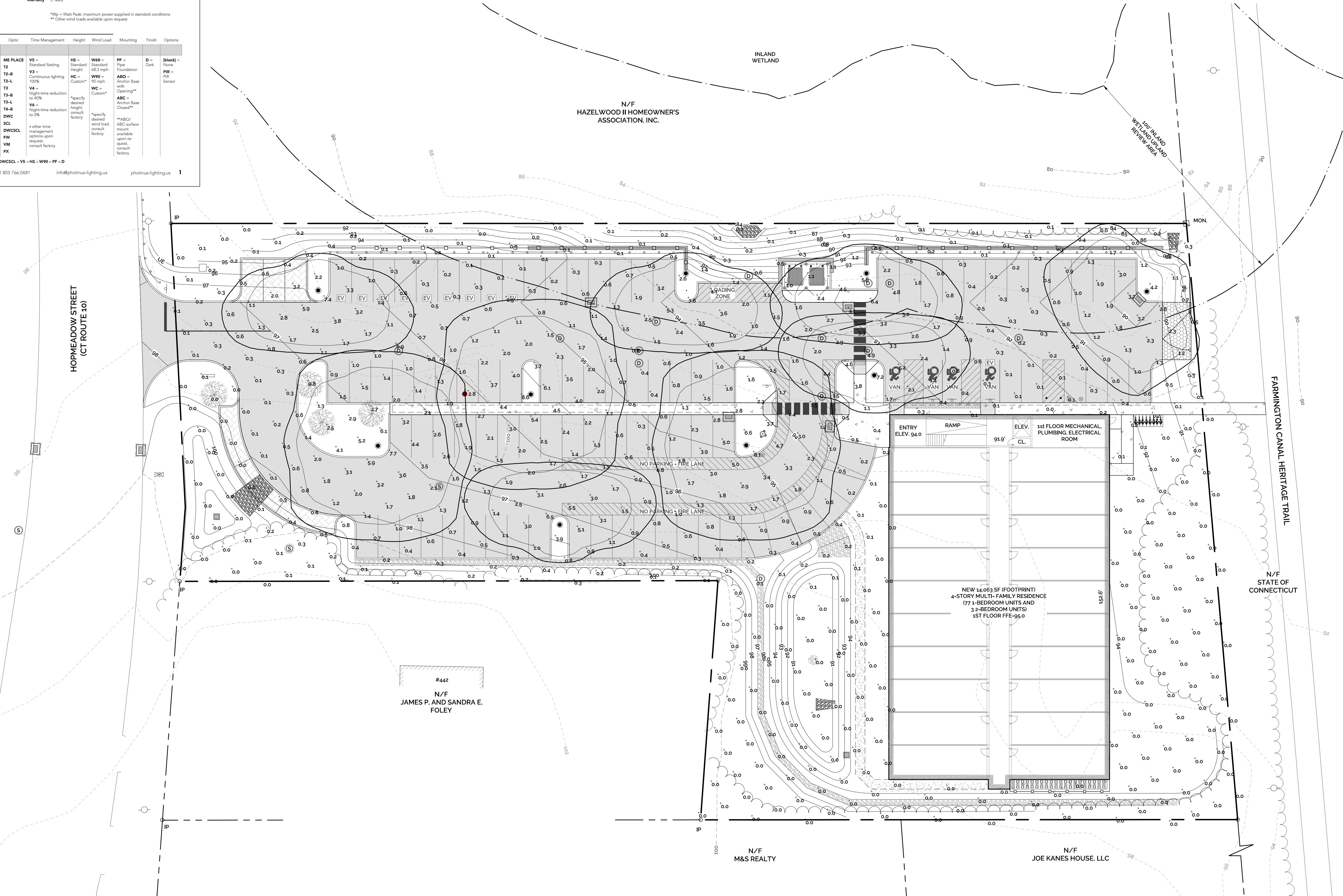

H+H ENGINEERING ASSOCIATES
 232 Greenmanville Avenue
 Suite 201
 Mystic, CT 06355
 860-980-8008 (C) 413-579-4488 (M)
 www.hh-engineers.com

STAMP

REV	DATE	DESCRIPTION OF REVISION	SHM	APPR.
2	3/17/2023	REVISIONS PER ENGINEERING REVIEW COMMENTS & IWA COMMENTS	SHM	
1	2/24/2023	REVISIONS PER REVIEW COMMENTS	SHM	

SITE PHOTOMETRIC PLAN
VESSEL MULTI-FAMILY HOUSING
 PROPERTY ADDRESS
 446 HOPMEADOW STREET, SIMSBURY, CT 06089
 PREPARED FOR
VESSEL RE HOLDINGS, LLC
 46 WEST 55TH STREET, NEW YORK, NY 10019

N

SCALE IN FEET
 20 10 0 10 20
 1" = 20'

PROJECT NO. 2022-0013	SCALE 1" = 20'
DRAWN BY: SMM	DATE 12/16/2022
CHECKED BY: SMM	DATE 12/16/2022

DRAWING
SPP-1
 SHEET NUMBER: 6 OF 12

2: SIMSBURY ENGINEERING ASSOCIATES PROJECTS \2022\2022-0013 - VESSEL - 446 HOPMEADOW ST, SIMSBURY\DWGS\PHOTOMETRIC PLAN\DWG THE PHOTOMETRIC PLAN Saved: 3/17/2023 3:46 PM

STAMP

REV	DATE	DESCRIPTION OF REVISION
1	2/24/2023	REVISIONS PER REVIEW COMMENTS
2	3/17/2023	REVISIONS PER ENGINEERING REVIEW COMMENTS & IWA COMMENTS

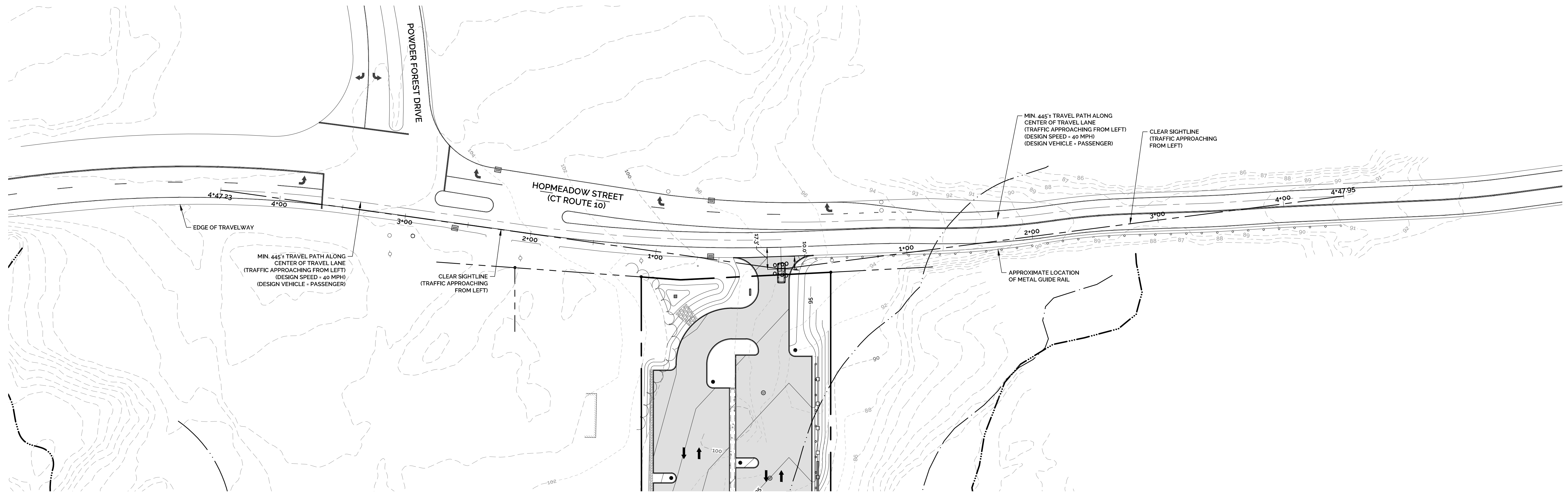

SIGHTLINE PLAN
SCALE: 1" = 40'

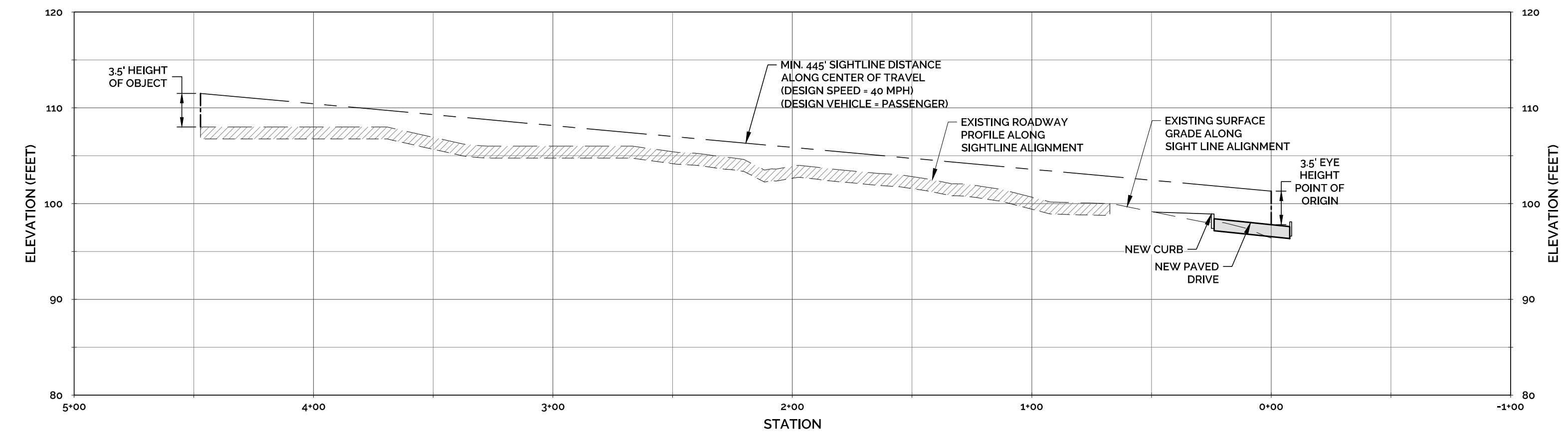

SIGHTLINE PROFILE - LOOKING SOUTH
HORIZONTAL SCALE: 1" = 40'
VERTICAL SCALE: 1" = 10'

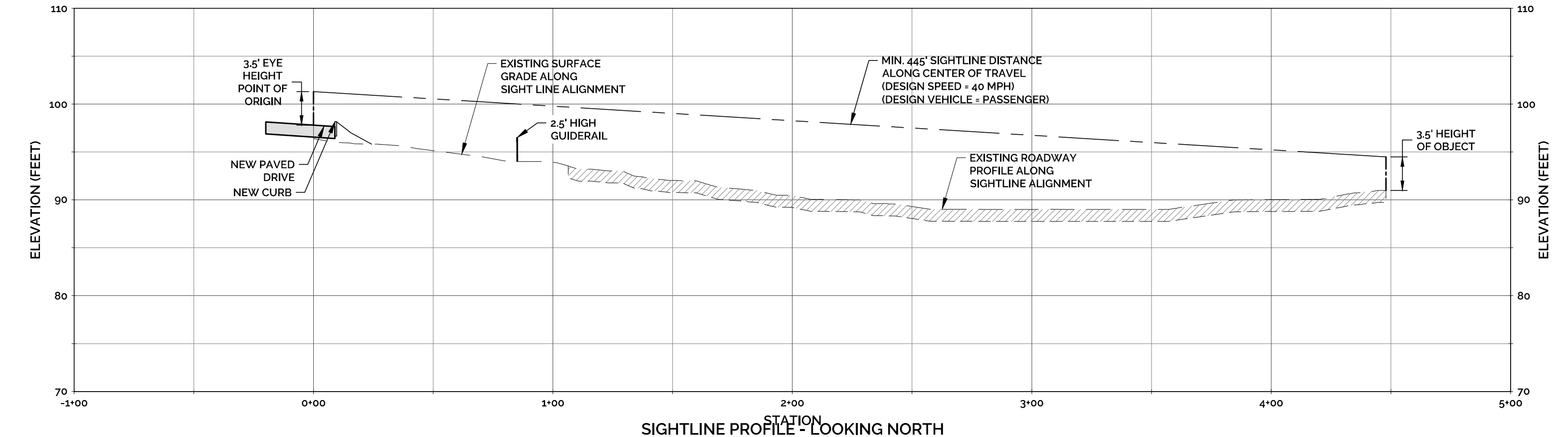

SIGHTLINE PROFILE - LOOKING NORTH
HORIZONTAL SCALE: 1" = 40'
VERTICAL SCALE: 1" = 10'

SIGHTLINE DEMONSTRATION PLAN

VESSEL MULTI-FAMILY HOUSING
PROPERTY ADDRESS
446 HOPMEADOW STREET, SIMSBURY, CT 06089
PREPARED FOR
VESSEL RE HOLDINGS, LLC
46 WEST 55TH STREET, NEW YORK, NY 10019

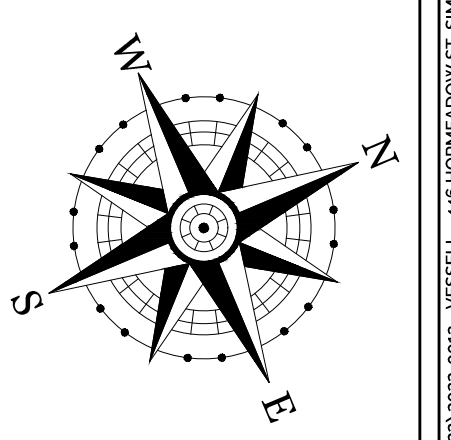

SCALE IN FEET

40 20 0 20 40

PROJECT NO. 2022-0013	SCALE 1" = 20'
DRAWN BY: SMM	DATE 12/16/2022
CHECKED BY: SMM	DATE 12/16/2022

DRAWING
ST-1

SHEET NUMBER: 7 OF 12

Z:\SHARED\H+H ENGINEERING ASSOCIATES\PROJECTS\2022\2022-0013 - VESSEL - 466 HOPMEADOW ST, SIMSBURY\DWGS\07-SIGHTLINE DEMONSTRATION PLAN\DWG Tab: SIGHTLINE_Sheet2 3/17/2023 3:53 PM

SOIL EROSION & SEDIMENTATION CONTROL PLAN:

PROJECT DESCRIPTION

- THE APPLICANT IS PROPOSING TO DEMOLISH THE EXISTING BUILDING AND IMPROVEMENTS AND CONSTRUCT A NEW FOUR-STORY, 140,000 SQ. FT. MULTI-FAMILY RESIDENTIAL BUILDING, CONSISTING OF 77 ONE-BEDROOM UNITS AND 3 TWO-BEDROOM UNITS FOR A TOTAL OF 80 UNITS. SITE IMPROVEMENTS WILL INCLUDE A NEW TWO-WAY ACCESS DRIVE FROM HOPMEADOW ROAD (CT ROUTE 10), A NEW 95 VEHICLE PARKING LOT, NEW UTILITY CONNECTIONS, NEW LANDSCAPING IMPROVEMENTS, AND A NEW STORMWATER MANAGEMENT SYSTEM. THE DEVELOPMENT IS BEING PERMITTED IN ACCORDANCE WITH GENERAL STATUTES § 202c-205.
- CONSTRUCTION IS ANTICIPATED TO COMMENCE IN FALL 2023. ALL SOIL EROSION & SEDIMENTATION CONTROLS (SESC) SHALL BE INSTALLED PRIOR TO CONSTRUCTION ACTIVITIES. ALL SESC SHALL BE MAINTAINED AND REPAIRED OR REPLACED AS NEEDED THROUGHOUT THE CONSTRUCTION DURATION. SESC SHALL BE REMOVED AND PROPERLY DISPOSED OF AS SOON AS THE SITE IS COMPLETELY STABILIZED.
- THE TOPOGRAPHY IS MODERATE, SLOPING DOWN FROM ELEVATION 102.2 ALONG THE SOUTHERN PROPERTY LINE TO ELEVATION 84 ALONG THE NORTHERN PROPERTY LINE. THE EXISTING SITE IS DEVELOPED AS A SINGLE-FAMILY RESIDENCE. PER NRCS SOIL MAPPING, THE UNDERLYING SOIL ON THE SITE MOSTLY CONSISTS OF HINCKLEY LOAMY SAND, HYDROLOGIC SOIL GROUP A.
- A LARGE PORTION OF THE UPLAND SOILS WILL BE DISTURBED BY EARTHWORK ACTIVITIES AND THE INTENT OF THIS SESC PLAN IS TO ESTABLISH STORMWATER CONTROLS DURING CONSTRUCTION TO PREVENT THE DISCHARGE OF SEDIMENT LADEN RUNOFF FROM ENTERING STORM DRAIN SYSTEMS, WETLANDS AND/OR WATERCOURSES.
- THE PROJECT DEVELOPMENT WILL REQUIRE DEMOLITION AND CLEARING OF APPROXIMATELY 1.8 ACRES OF AREA AND EARTHWORK TO PREPARE THE BUILDING SITE. EARTHWORK ACTIVITIES WILL EXPOSE SOILS TO EROSION DURING RAINFALL EVENTS.

GENERAL SESC REQUIREMENTS

- THE SITE CONTRACTOR MUST FOLLOW ALL GUIDELINES SET FORTH IN THE MANUAL ENTITLED "2002 CONNECTICUT GUIDELINES FOR SOIL EROSION AND SEDIMENT CONTROL" PUBLISHED BY THE CONNECTICUT COUNCIL ON SOIL AND WATER CONSERVATION IN COOPERATION WITH THE CONNECTICUT DEPARTMENT OF ENVIRONMENTAL PROTECTION. THIS MANUAL IS ALSO KNOWN AS DEP BULLETIN 34.
- SESC MEASURES INTENDED TO MINIMIZE SOIL EROSION AND TO CONTROL SEDIMENTATION DURING CONSTRUCTION INCLUDE:
 - THE INSTALLATION OF SILT FENCE AND/OR STAKED HAYBALES ALONG THE DOWNGRADE LIMIT OF DISTURBANCE.
 - THE IMMEDIATE STABILIZATION OF DISTURBED AREAS THROUGH THE PLACEMENT OF TEMPORARY SEED AND MULCH OR FINAL TOPSOIL, SEED AND MULCH.
 - CONSTRUCTION OF TEMPORARY SEDIMENT TRAPS.
 - THE USE OF EROSION CONTROL BLANKETS TO STABILIZED CUT AND FILL SLOPES GRADED AT 3H:1V OR STEEPER. EROSION CONTROL BLANKET SHALL BE NORTH AMERICAN GREEN BIONET ROLLMAX BIONET C2325N AS MANUFACTURED BY NORTH AMERICAN GREEN, LOCATED AT 4509 E. BOONVILLE-NEW HARMONY ROAD, EVANSVILLE, INDIANA, 47725.
 - DEVELOPMENT OF A CONSTRUCTION OPERATIONS PLAN IN CONSIDERATION OF BASIC CONSTRUCTION SEQUENCING OUTLINED HEREIN.
- ALL ADJACENT PROPERTIES SHALL BE ADEQUATELY PROTECTED FROM SOIL EROSION AND SEDIMENTATION BOTH DURING AND AFTER CONSTRUCTION.
- CONSTRUCTION ENTRANCE SHALL BE INSTALLED BEFORE CONSTRUCTION TRAFFIC INTO AND OUT OF THE SITE BEGINS.
- THE CONTRACTOR SHALL INSTALL SILT FENCING PRIOR TO INITIATING CONSTRUCTION ACTIVITIES AND SHALL BE MAINTAINED/REPAIRED UNTIL FINAL STABILIZATION OF ALL DISTURBED AREAS.
- ALL AREAS SHALL REMAIN UNDISTURBED UNTIL IMMEDIATELY PRIOR TO SITE DEVELOPMENT.
- ALL EXISTING VEGETATION OUTSIDE OF THE LIMITS OF DISTURBANCE SHALL BE PROTECTED. EXISTING VEGETATION SHALL BE REMOVED ONLY IN AREAS NECESSARY FOR SITE CONSTRUCTION ACTIVITIES.
- ALL CONSTRUCTION EQUIPMENT, MATERIALS AND STOCKPILES SHALL NOT BE PLACED OUTSIDE OF THE DISTURBED AREAS.
- THE CONTRACTOR SHALL SEED AND MULCH DISTURBED AREAS EXPECTED TO REMAIN UNSTABILIZED FOR A PERIOD OF MORE THAN 30 DAYS.
- THE CONTRACTOR SHALL COMPLETE PERMANENT SEEDING BETWEEN APRIL 1ST THROUGH JUNE 15TH AND AUGUST 15TH THROUGH OCTOBER 1ST. APPLY PERMANENT SOIL STABILIZATION MEASURES TO ALL GRADED AREAS WITHIN 7 DAYS OF ESTABLISHING FINAL GRADE AT A RATE OF 90 POUNDS PER 1,000 SQUARE FEET. RECOMMENDED SEED MIXTURE: FUTURA 2000 BY THE CHAS. C. HART CO. CONTAINING THE FOLLOWING VARIETIES OF PERENNIAL RYEGRASSES: FIESTA II, BLAZER B, DASHER B AND EXPRESS.
- THE CONTRACTOR SHALL BE RESPONSIBLE FOR THE PROPER INSTALLATION AND MAINTENANCE OF ALL SESC BEFORE, DURING AND AFTER CONSTRUCTION. THE CONTRACTOR IS ALSO RESPONSIBLE FOR THE PROPER REMOVAL AND DISPOSAL OF ALL EROSION AND SEDIMENT CONTROL DEVICES ONCE THE SITE IS COMPLETELY STABILIZED.
- ALL SESC SHALL BE INSPECTED WEEKLY AND AFTER ALL RAINFALL EVENTS. ALL SESC SHALL BE REPAIRED OR REPLACED AS NECESSARY WITHIN 24 HOURS THROUGHOUT THE CONSTRUCTION DURATION.

CONSTRUCTION SEQUENCE

- CONTACT "CALL BEFORE YOU DIG" TO MARK OUT ALL UTILITY LOCATIONS PRIOR TO ANY CONSTRUCTION ACTIVITIES.
- ENSURE ALL LAND USE PERMITS HAVE BEEN SECURED. OBTAIN ALL NECESSARY PERMITS.
- INSTALL TEMPORARY CONSTRUCTION ENTRANCE, SEDIMENT FENCE AND/OR HAY BALE BARRIERS AS SHOWN ON THE SESC PLAN.
- DISCONNECT UTILITIES ON BUILDING TO BE REMOVED.
- DEMOLISH AND REMOVE EXISTING BUILDING, STRUCTURES AND ASSOCIATED SITE IMPROVEMENTS.
- REMOVE ALL TREES, BRUSH AND STUMPS WITHIN LIMIT OF DISTURBANCE AS NECESSARY. THERE SHALL BE NO BURIAL OF CONSTRUCTION DEBRIS, STUMPS, BRUSH OR UNSUITABLE MATERIAL ON SITE.
- REMOVE AND STOCKPILE ALL TOPSOIL ON SITE AND PROVIDE A SEDIMENT FENCE ON THE DOWNSLOPE SIDE. SEED STOCKPILES WITH PERENNIAL RYEGRASS AT A RATE OF 40 POUNDS PER ACRE AND MULCH WITH HAY OR STRAW IF OUTSIDE THESE GROWING SEASON. AREAS SHALL BE STABILIZED WITH STRAW OR HAY MULCHING AT A RATE OF 90 POUNDS PER 1,000 SQUARE FEET.
- CONSTRUCT TEMPORARY SEDIMENT TRAP. GRADE DISTURBED AREAS TO DRAIN TO THE TEMPORARY SEDIMENT TRAP USING TEMPORARY DIVERSION SWALES. NO DISTURBED SURFACES SHALL BE GRADED TOWARD THE WETLANDS.
- EXCAVATE AND/OR FILL WORK SITE TO SUBGRADE LEVEL.
 - NO ROCK CRUSHING AND/OR BLASTING IS PROPOSED. IF BLASTING IS REQUIRED FOR ROCK REMOVAL, A PRE-BLAST SURVEY SHALL BE PERFORMED. IF BLASTING AND ROCK CRUSHING ARE REQUIRED THEN APPROVAL OF THE PLANNING AND ZONING COMMISSION IS REQUIRED.
 - FILL WILL BE PLACED AND COMPACTED IN 8 INCH LIFTS AND SHALL BE FREE OF BRUSH, RUBBISH, LOGS, BUILDING DEBRIS, OR ANY OTHER OBJECTIONABLE MATERIAL. CONSTRUCT RETAINING WALLS AS REQUIRED.
 - MOISTEN SOIL SURFACE PERIODICALLY WITH WATER TO MINIMIZE DUST.
- BEGIN CONSTRUCTION OF BUILDING AND INSTALL UTILITIES. MAINTAIN TEMPORARY DRAINAGE TO SEDIMENT TRAP. ADD EROSION CONTROL DEVICES AS NEEDED.
- INSTALL STORMWATER MANAGEMENT IMPROVEMENTS AND DRAINAGE STRUCTURES STARTING FROM THE MOST DOWNGRADE IMPROVEMENTS. INSTALL FILTER FABRIC AND/OR HAY BALES AT CATCH BASINS IMMEDIATELY AFTER CATCH BASIN INSTALLATION.
- PLACE AND COMPACT BASE MATERIAL TO FINAL GRADE. INSTALL PAVEMENT BASE COURSE, CURB, SIDEWALKS, STEPS, ETC.
- ALL DISTURBED AREAS NOT COVERED BY BUILDINGS, PARKING, SIDEWALKS, ETC., SHALL BE GRADED AND STABILIZED AS FOLLOWS:
 - PLACE MINIMUM 4 INCHES OF TOPSOIL IN ALL AREAS.
 - APPLY RECOMMENDED SEED MIXTURE AT RECOMMENDED RATE.
 - APPLY STRAW OR HAY MULCH ON ALL SEEDING AREAS. ALL GRADED AREAS WITH SLOPES GRADED AT 3H:1V OR STEEPER SHALL BE STABILIZED WITH EROSION CONTROL BLANKETS.
- INSTALL FINAL PAVEMENT COURSE.
- FINAL GRADE AND PLACE TOPSOIL, SEED AND MULCH.
- WHEN ALL GRADED AREAS ARE PERMANENTLY STABILIZED, REMOVE ALL EROSION AND SEDIMENT CONTROLS. REMOVE TRAPPED SEDIMENT.

TRENCH EXCAVATION AND BACKFILL

- THE CONTRACTOR SHALL PROPERLY MAINTAIN ALL BACKFILLED EXCAVATIONS, ANY DEPRESSIONS DUE TO SETTLING IN THESE AREAS SHALL BE FILLED AND RESEDED AS NECESSARY.
- THE WIDTH OF ALL EXCAVATED TRENCHES SHALL BE KEPT AS NARROW AS PRACTICABLE TO ACCOMMODATE THE WORK. ALL MATERIALS SHALL BE STOCKPILED AND USED AS TRENCH BACKFILL MATERIAL UNLESS IT IS DETERMINED TO BE UNSUITABLE BY THE ENGINEER. EXCESS MATERIALS SHALL BE PROPERLY DISPOSED OF BY THE CONTRACTOR.

VEGETATIVE TURF ESTABLISHMENT PROCEDURE

- SCARIFY ALL AREAS TO BE TOPSOILED AND SEED. APPLY A MINIMUM OF 1/4 INCHES OF TOPSOIL ON ALL AREAS TO BE SEED. APPLY GRASS SEED, LIME, FERTILIZER AND MULCH ACCORDING TO THE FOLLOWING SCHEDULE.
- PERMANENT SEED MIXTURE:

CREeping RED FESCUE	0.45 LBS. PER 1,000 SQ. FT.
REDTOP	0.05
TALL FESCUE	0.45
TOTAL	0.95
- FERTILIZER:

10-10-10 APPLY AT 7.5 LBS. PER 1,000 SQ. FT.
--
- LIMESTONE:

APPLY AT 150 LBS. PER 1,000 SQ. FT.

- MULCHING:

SPREAD HAY OR STRAW OVER ALL AREAS AFTER SEEDING. USE 1/2 TO 2 BALES PER 1,000 SQ. FT. TARGET FOR 100% COVERAGE. ANCHOR BY USING NETTING OR TRACKING AS NECESSARY.
--
- TEMPORARY EROSION CONTROL BLANKETS:

USE TEMPORARY EROSION CONTROL BLANKETS ON ALL SEEDING SLOPES GRADED AT 3H:1V OR STEEPER AND/OR AS DIRECTED BY THE DESIGN ENGINEER.
--
- SEEDING DATES:

SEEDING DATES IN CONNECTICUT ARE NORMALLY APRIL 1 THROUGH JUNE 15 AND AUGUST 15 THROUGH OCTOBER 1. SEED GERMINATION CANNOT BE EXPECTED FROM NOVEMBER THROUGH FEBRUARY. IF ADEQUATE SEED GERMINATION IS NOT POSSIBLE DUE TO TIME OF YEAR CONSTRAINTS, MULCHING SHALL BE ADEQUATELY PROVIDED TO PROTECT THE SEED FROM WIND AND SURFACE EROSION UNTIL THE WEATHER IMPROVES AND THE SEEDING BECOMES WELL ESTABLISHED.

MAINTENANCE OF EROSION CONTROL DEVICES:

HAYBALE BARRIERS/GEOTEXTILE SILT FENCES:

- INSPECT HAY BALE BARRIERS/GEOTEXTILE SILT FENCE AT LEAST ONCE A WEEK AND WITHIN 24 HOURS AFTER THE END OF A STORM WITH A RAINFALL AMOUNT OF 1/2" OR GREATER TO DETERMINE MAINTENANCE NEEDS.
- REMOVE SEDIMENT DEPOSITS OR INSTALL A SECONDARY BARRIER/FENCE WHEN SEDIMENT DEPOSITS REACH APPROXIMATELY ONE HALF HEIGHT OF THE BARRIER/FENCE.
- REPLACE OR REPAIR THE BARRIER/FENCE WITHIN 24 HOURS OF OBSERVED FAILURE. IF REPETITIVE FAILURE OCCURS, CONSULT 2002 GUIDELINES FOR TRENCH EXCAVATION FAILURES.
- MAINTAIN THE HAY BALE BARRIER/SILT FENCE UNTIL THE CONTRIBUTING AREA IS STABILIZED.
- AFTER UPSLOPE AREAS HAVE BEEN PERMANENTLY STABILIZED, REMOVE STAKES FROM HAY BALES. PULL UP FENCE SUPPORT POSTS AND CUT OFF GEOTEXTILE AT GROUND, UNLESS OTHERWISE REQUIRED. HAY BALES MAY BE LEFT IN PLACE OR BROKEN UP FOR GROUND COVER. IF ACCUMULATED SEDIMENT EXCEEDS 6 INCHES, RE-GRADE OR REMOVE SEDIMENT. STABILIZE ANY DISTURBED SOILS.

CONSTRUCTION ENTRANCES AND ROADWAYS:

- MAINTAIN THE ENTRANCE IN A CONDITION WHICH WILL PREVENT TRACKING AND WASHING OF SEDIMENTS ONTO PAVED SURFACES.
- PROVIDE PERIODIC TOP DRESSING AND ADDITIONAL STONE OR LENGTH AS NECESSARY.
- IMMEDIATELY REMOVE ALL SEDIMENT SPILLED, DROPPED, WASHED OR TRACKED ONTO PAVED SURFACES. ROADS ADJACENT TO THE CONSTRUCTION SITE SHALL BE LEFT CLEAN EVERY DAY.

TEMPORARY SEDIMENT TRAP:

- INSPECTIONS SHALL BE AT SAME INTERVALS AS THE HAYBALE BARRIER/SILT FENCE INSPECTION SCHEDULE.
- OUTLET SHALL BE CHECKED FOR INTEGRITY. HEIGHT OF THE STONE OUTLET SHALL BE MAINTAINED AT ONE FOOT BELOW CREST OF EMBANKMENT. SEDIMENT ACCUMULATION AND FILTRATION PERFORMANCE SHOULD BE OBSERVED.
- WHEN SEDIMENTS HAVE ACCUMULATED TO ONE HALF OF THE MINIMUM REQUIRED STORAGE VOLUME, DE-WATER BASIN, REMOVE SEDIMENTS, RESTORE TRAP TO ORIGINAL DIMENSIONS AND DISPOSE OF SEDIMENT AT A LOCATION AND MANNER THAT WILL NOT RESULT IN EROSION OR SEDIMENTATION.

- AFTER CONTRIBUTING AREA IS STABILIZED, REMOVE BASIN, AND RE-GRADE AND STABILIZE AREA.

TEMPORARY DIVERSION DITCHES/SWALES:

- WHEN THE TEMPORARY DIVERSION IS LOCATED IN CLOSE PROXIMITY TO ONGOING CONSTRUCTION ACTIVITIES, INSPECT AT THE END OF EACH DAY AND IMMEDIATELY REPAIR DAMAGES, OTHERWISE, INSPECT ON SAME INTERVAL AS THE TEMPORARY SEDIMENT TRAP.
- REPAIR THE DIVERSION WITHIN 24 HOURS OF ANY OBSERVED FAILURE. FAILURE HAS OCCURRED WHEN THE DIVERSION HAS BEEN DAMAGED SUCH THAT IT NO LONGER MEETS THE SPECIFICATIONS IN THE 2002 GUIDELINES.
- IF REPETITIVE FAILURES OCCUR, REVIEW CONDITIONS AND DETERMINE IF ADDITIONAL MEASURES OR AN ALTERNATIVE MEASURE IS NECESSARY.

CONCRETE WASHOUT AREA:

- WASHOUT AREA TO BE INSPECTED AT LEAST ONCE A WEEK FOR STRUCTURAL INTEGRITY, ADEQUATE HOLDING CAPACITY AND CHECKED FOR LEAKS, TEARS, OR OVERFLOWS. CHECK AFTER HEAVY RAINS.
- HARDENED CONCRETE WASTE SHOULD BE REMOVED AND DISPOSED OF WHEN THE WASTE HAS ACCUMULATED TO HALF OF THE CONCRETE WASHOUT'S DEPTH. THE WASTE CAN BE STORED AT AN UPLAND LOCATION, AS APPROVED BY ENGINEER. ALL CONCRETE WASTE SHALL BE DISPOSED OF IN A MANNER CONSISTENT WITH ALL APPLICABLE LAWS, REGULATIONS, AND GUIDELINES.

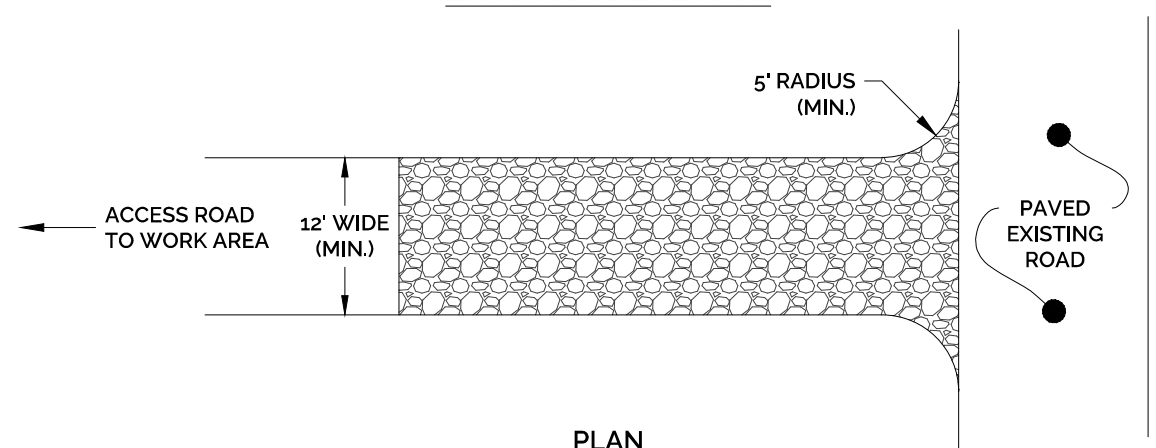
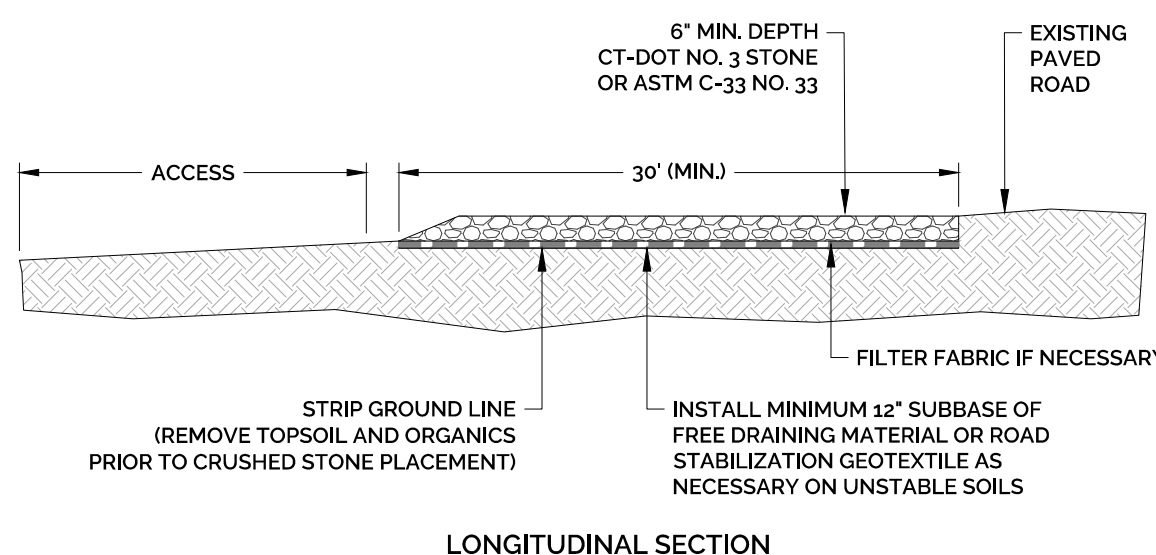

NOTE: ALL ANTI-TRACKING PADS SHALL BE INSTALLED AND MAINTAINED IN ACCORDANCE WITH 2002 CT GUIDELINES FOR SOIL EROSION & SEDIMENT CONTROL, AS AMENDED. REFERENCE: 2002 CT GUIDELINES FOR EROSION AND SEDIMENT CONTROL, DEEP BULLETIN 34, FIGURE CE-2, ERRATA DATA 3/17/06, PAGE 5-12-4 (4" STONE NOW 6" STONE).

ANTI-TRACKING PAD DETAIL

NOT TO SCALE

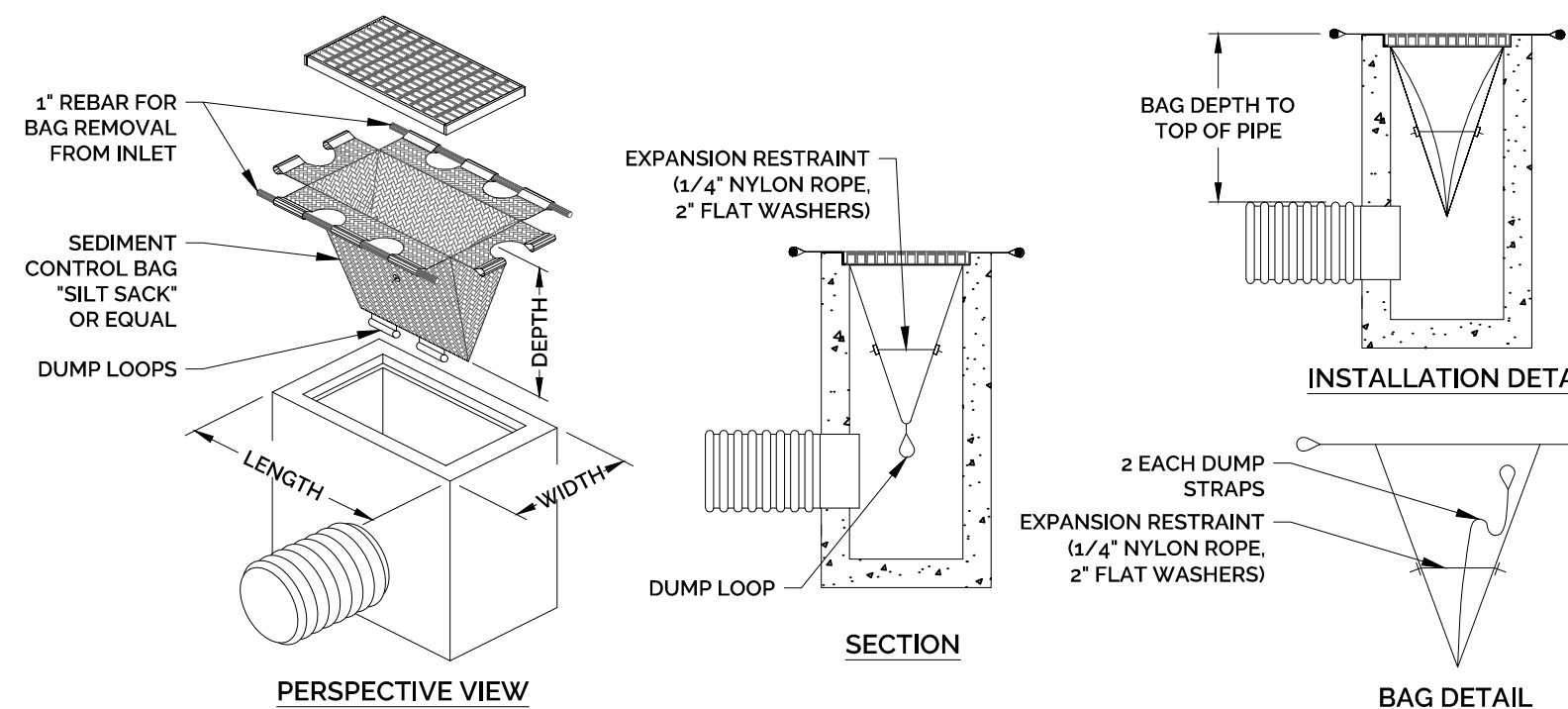

NOTES:

- THE CONTRACTOR IS RESPONSIBLE FOR PROVIDING THE CORRECT SIZE DEVICE FOR EACH INLET. FOR NON-STANDARD CATCH BASINS AND INLETS, THE CONTRACTOR SHALL MEASURE DIMENSIONS IN THE FIELD AND ORDER THE APPROPRIATE SIZE(S).
- THE INLET SEDIMENT CONTROL DEVICE SHALL BE OF HIGH FLOW DESIGN (200 GAL./MIN./FT.), AS PER THE MANUFACTURER'S SPECS.
- THE SEDIMENT CONTROL DEVICE SHALL BE INSPECTED DAILY BY THE CONTRACTOR AND CLEANED AND MAINTAINED A MINIMUM ONCE PER MONTH OR WITHIN THE 48 HOURS FOLLOWING A STORM EVENT. THE FILTER SHALL BE REPLACED OR CLEANED WHEN THE BAG BECOMES HALF FULL. THE FILTER SHALL BE CLEANED IN A MANNER WHICH ENSURES THAT ALL SEDIMENT REMAINS ON SITE.
- SUBSTITUTION OF A SHEET OF FILTER FABRIC PLACED OVER THE OPENING OF THE INLET IS NOT APPROVED.
- RECESSED CURB INLET CATCH BASINS MUST BE BLOCKED WHEN USING FILTER FABRIC INLET SACKS. SIZE OF FILTER INLET SACK TO BE DETERMINED BY MANUFACTURER.
- THE FILTER DEVICE SHALL BE MANUFACTURED BY ACF ENVIRONMENTAL OR APPROVED EQUAL.

CATCH BASIN FILTER (SILT SACK) DETAIL

NOT TO SCALE

ITEM	TEMPORARY SEDIMENT TRAP
DRAINAGE AREA (ACRES)	2.00
TOTAL STORAGE VOLUME REQUIRED (CF)	7,236
WET STORAGE VOLUME REQUIRED (CF)	3,618
DRY STORAGE VOLUME REQUIRED (CF)	3,618

NOTES:

- PERVIOUS STONE DIKE SHALL BE CONSTRUCTED OF CT DOT MODIFIED RIPRAP WITH #3 STONE ON FACE.
- NON-OVERFLOW PORTIONS AND ABUTMENTS OF TEMPORARY SEDIMENT TRAP MAY BE CONSTRUCTED OF COMPACTED EARTH FILL.

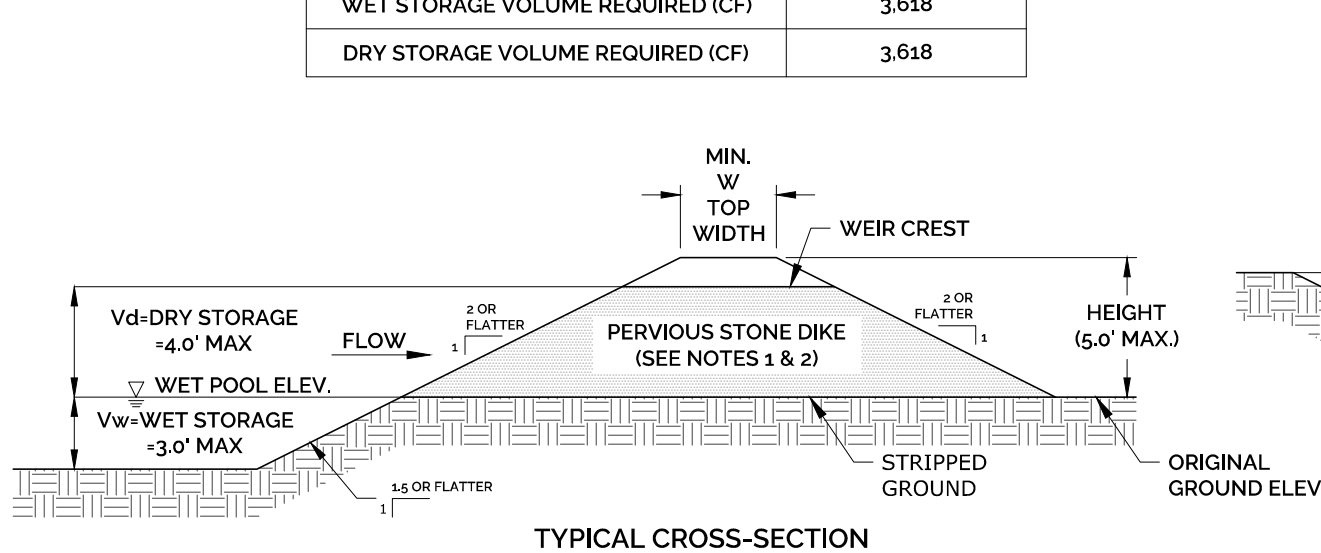

NOTE: TEMPORARY SEDIMENT TRAP SHALL BE SIZED BASED ON A MINIMUM OF 134 CUBIC YARDS OF WATER STORAGE PER ACRE DRAINED, A MINIMUM WET STORAGE VOLUME EQUAL TO HALF OF THE TOTAL STORAGE VOLUME AND A MINIMUM DRY STORAGE VOLUME EQUAL TO HALF OF THE TOTAL STORAGE VOLUME.

TEMPORARY SEDIMENT TRAP DETAIL

NOT TO SCALE

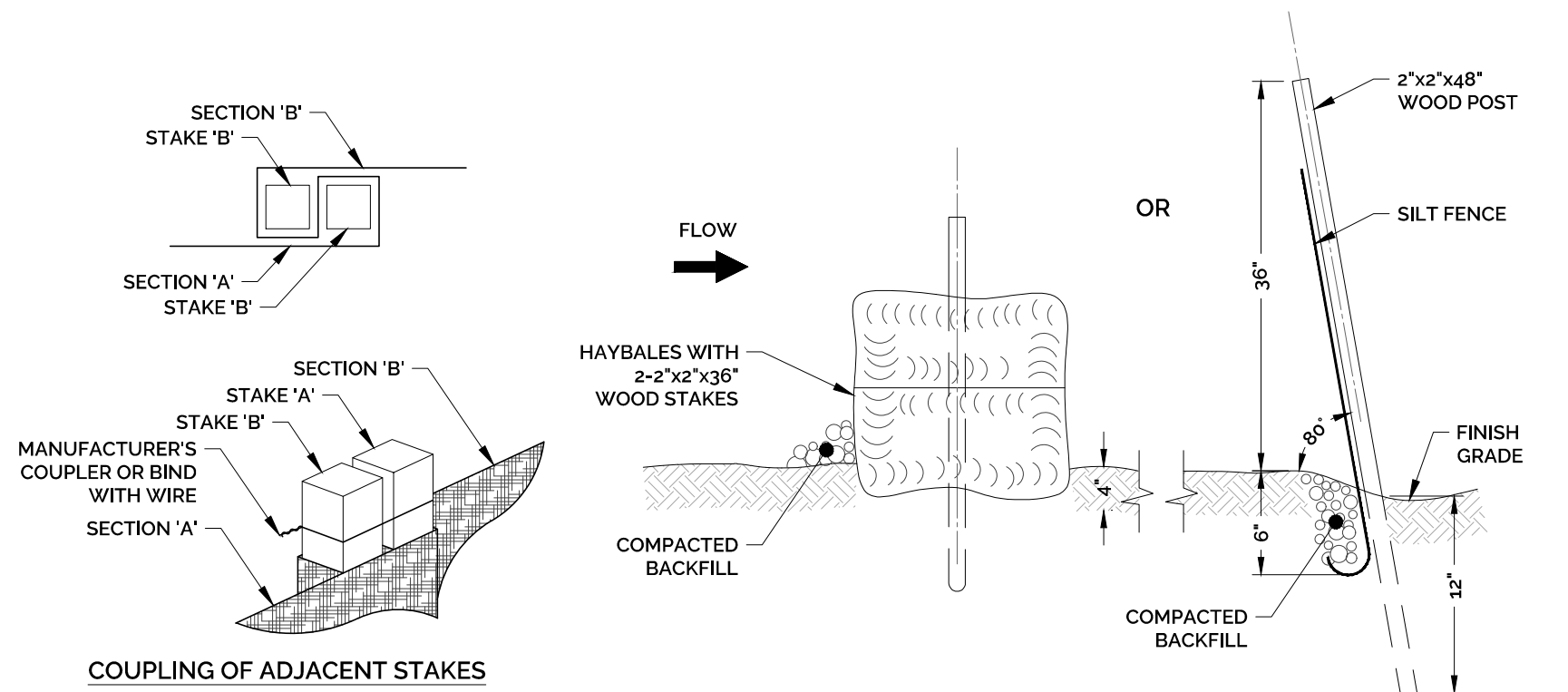
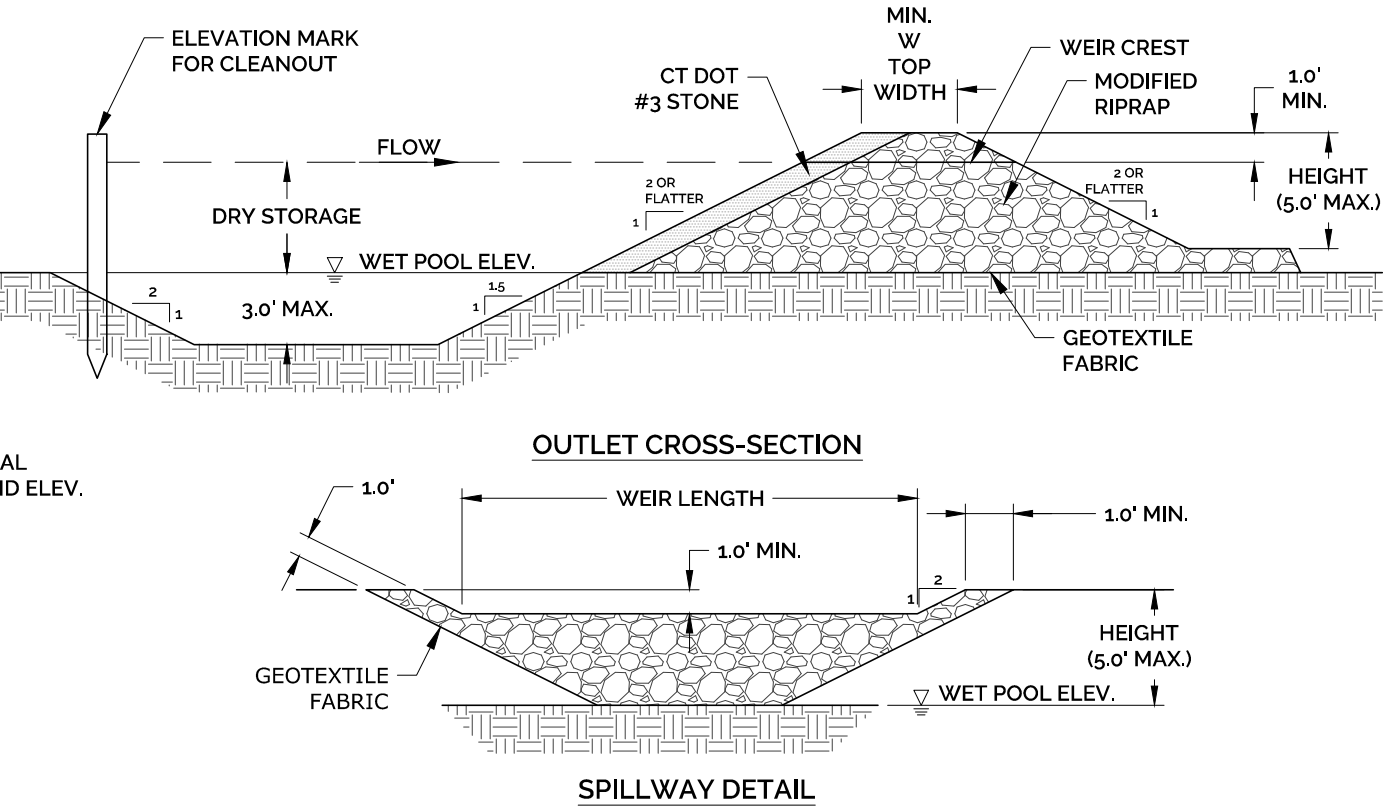

INSTALLATION NOTES FOR HAY BALES:

- PLACE HAY BALES ON CONTOUR AND WITH LAST HAY BALES UPSLOPE TO THAT TOP OF LAST SEVERAL HAY BALES ARE HIGHER THAN LINE OF HAY BALES.
- EXCAVATE TRENCH 4" MIN. AND PLACE FILL UPSLOPE OF TRENCH.
- PLACE HAY BALE AND STAKE FIRST STAKE AT ANGLE TOWARDS FIRST BALE. STAKES ARE 18" MIN. INTO GROUND.
- WEDGE LOOSE HAY BETWEEN BALES.
- BACKFILL & COMPACT EXCAVATED FILL ALONG UPHILL SIDE OF HAY BALE.

TYPICAL SEDIMENT BARRIER DETAIL

NOT TO SCALE

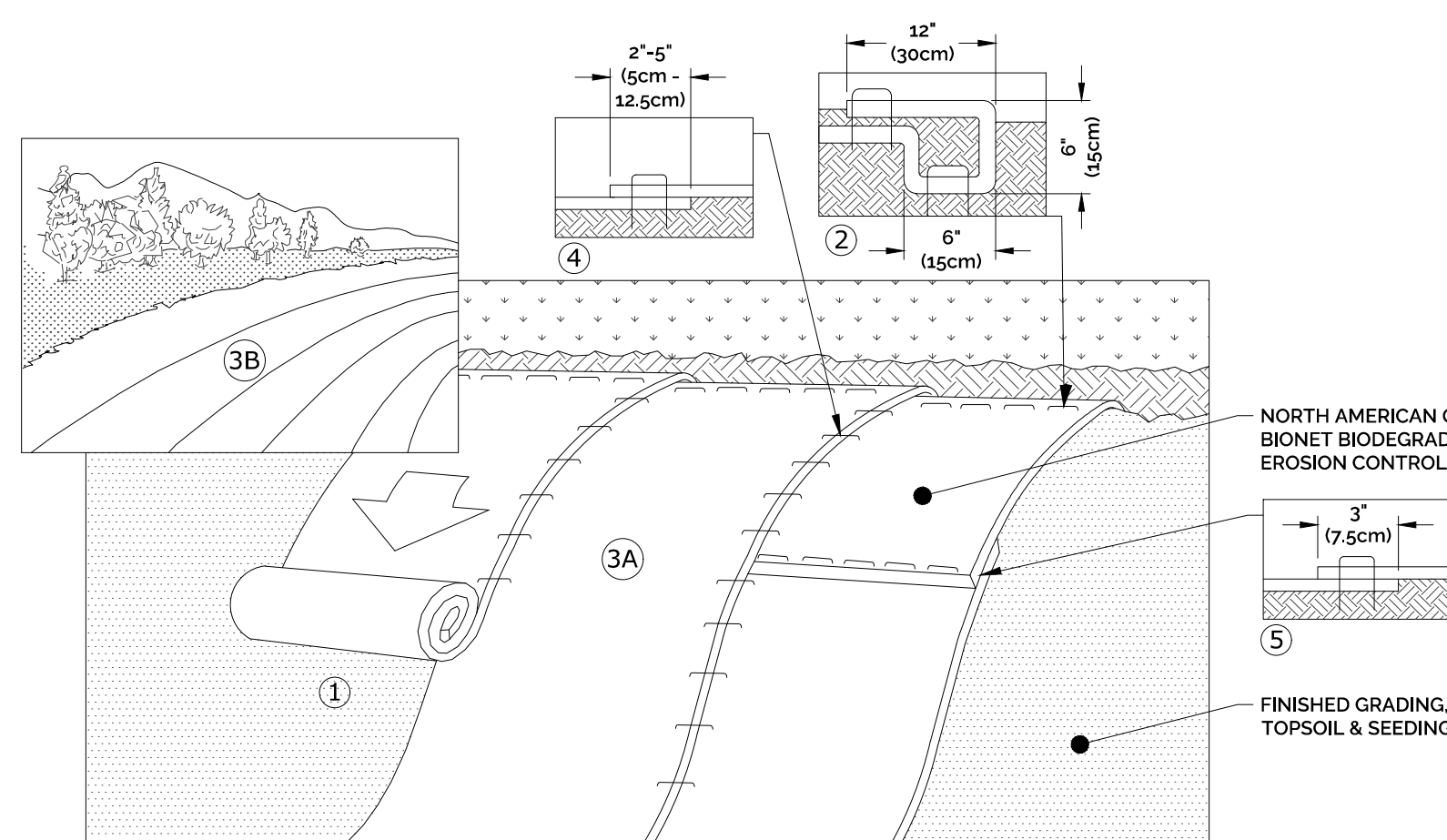

NOTES:

- PREPARE SOIL BEFORE INSTALLING BLANKETS, INCLUDING ANY NECESSARY APPLICATION OF LIME, FERTILIZER, AND SEED. WHEN USING CELL-O-SEED DO NOT SEED PREPARED AREA. CELL-O-SEED MUST BE INSTALLED WITH PAPER SIDE DOWN.
- BEGIN AT THE TOP OF THE SLOPE BY ANCHORING THE BLANKET IN A 6" (15cm) DEEP x 6" (15cm) WIDE TRENCH WITH APPROXIMATELY 12" (30cm) OF BLANKET EXTENDED BEYOND THE UP-SLOPE PORTION OF THE TRENCH. ANCHOR THE BLANKET WITH A ROW OF STAPLES/STAKES APPROXIMATELY 12" (30cm) APART IN THE BOTTOM OF THE TRENCH. BACKFILL AND COMPACT THE TRENCH AFTER STAPLING. APPLY SEED TO COMPACTED SOIL AND FOLD REMAINING 12" (30cm) PORTION OF BLANKET BACK OVER SEED AND COMPACTED SOIL. SECURE BLANKET OVER COMPACTED SOIL WITH A ROW OF STAPLES/STAKES SPACED APPROXIMATELY 12" (30cm) APART ACROSS THE WIDTH OF THE BLANKET. IN LOOSE SOIL CONDITIONS, THE USE OF STAPLE OR STAKE LENGTHS GREATER THAN 6" (15 cm) MAY BE NECESSARY TO PROPERLY SECURE THE BLANKETS.
- ROLL THE BLANKETS (A) DOWN OR (B) HORIZONTALLY ACROSS THE SLOPE. BLANKETS WILL UNROLL WITH APPROPRIATE SIDE AGAINST THE SOIL SURFACE. ALL BLANKETS MUST BE SECURELY FASTENED TO SOIL SURFACE BY PLACING STAPLES/STAKES IN APPROPRIATE LOCATIONS AS SHOWN IN THE STAPLE PATTERN GUIDE. WHEN USING OPTIONAL DOT SYSTEM™, STAPLES/STAKES SHOULD BE PLACED THROUGH EACH OF THE COLORED DOTS CORRESPONDING TO THE APPROPRIATE STAPLE PATTERN.
- THE EDGES OF PARALLEL BLANKETS MUST BE STAPLED WITH APPROXIMATELY 2" x 5" (5cm x 12.5cm) OVERLAP DEPENDING ON BLANKET TYPE TO ENSURE PROPER SEAM ALIGNMENT. PLACE THE EDGE OF THE OVERLAPPING BLANKET (BLANKET BEING INSTALLED ON TOP) EVEN WITH THE COLORED SEAM STITCH™ ON THE PREVIOUSLY INSTALLED BLANKET.
- CONSECUTIVE BLANKETS SPLICED DOWN THE SLOPE MUST BE PLACED END OVER END (SHINGLE STYLE) WITH AN APPROXIMATE 3" (7.5cm) OVERLAP. STAPLE THROUGH OVERLAPPED AREA APPROXIMATELY 12" (30cm) APART ACROSS ENTIRE BLANKET WIDTH.

EROSION CONTROL BLANKET DETAIL

NOT TO SCALE

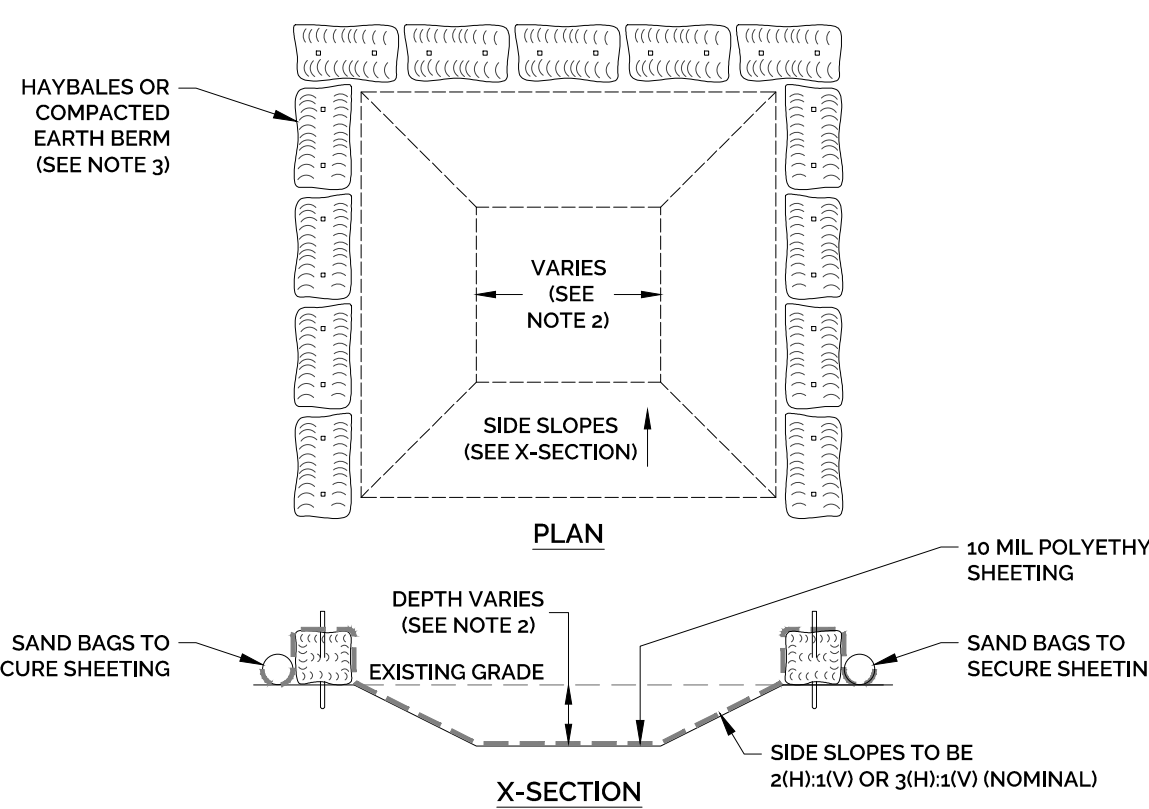

NOTES:

- CONCRETE WASHOUT AREAS SHALL BE INSTALLED PRIOR TO CONCRETE PLACEMENT ON SITE. THE CONCRETE WASHOUT AREA SHALL BE ENTIRELY SELF-CONTAINED.
- THE CONTRACTOR SHALL SUBMIT THE DESIGN, LOCATION AND SIZING OF THE CONCRETE WASHOUT AREAS WITH THE PROJECT'S EROSION & SEDIMENTATION CONTROL PLAN AND SHALL BE APPROVED BY THE ENGINEER.
- LOCATION WASHOUT AREAS ARE TO BE LOCATED AT LEAST 50 FEET FROM ANY STREAM, WETLAND, STORM DRAINS, OR OTHER SENSITIVE RESOURCE.
- SIZE: THE WASHOUT MUST HAVE SUFFICIENT VOLUME TO CONTAIN ALL LIQUID AND CONCRETE WASTE GENERATED BY WASHOUT OPERATIONS INCLUDING, BUT NOT LIMITED TO, OPERATIONS ASSOCIATED WITH GROUT AND MORTAR.
- SURFACE DISCHARGE IS UNACCEPTABLE. THEREFORE, HAYBALES OR OTHER CONTROL MEASURE SHOULD BE USED AROUND THE PERIMETER OF THE CONCRETE WASHOUT AREA FOR CONTAINMENT.
- SIGNS SHOULD BE PLACED AT THE CONSTRUCT ENTRANCE, AT THE CONCRETE AREAS AND ELSEWHERE AS NECESSARY TO CLEARLY INDICATE THE LOCATION OF THE CONCRETE WASHOUT TO OPERATORS OF CONCRETE TRUCKS AND PUMP RIGS. WASHOUT AREAS SHOULD BE FLAGGED WITH SAFETY FENCING OR OTHER APPROVED METHOD.
- WASHOUT AREAS ARE TO BE INSPECTED AT LEAST ONCE PER WEEK FOR STRUCTURAL INTEGRITY, ADEQUATE HOLDING CAPACITY AND CHECKED FOR LEAKS, TEARS OR OVERFLOWS. WASHOUT AREAS SHOULD BE CHECKED AFTER HEAVY RAINS.
- HARDENED CONCRETE WASTE SHOULD BE REMOVED AND DISPOSED OF WHEN THE WASTE HAS ACCUMULATED TO HALF OF THE CONCRETE WASHOUT'S DEPTH. THE WASTE CAN BE STORED AT AN UPLAND LOCATION AS APPROVED BY THE ENGINEER. ALL CONCRETE WASTE SHALL BE DISPOSED OF IN A MANNER CONSISTENT WITH ALL APPLICABLE LAWS, REGULATIONS AND GUIDELINES.

REFERENCE: STATE OF CONNECTICUT DEPARTMENT OF TRANSPORTATION OFFICE OF ENGINEERING CONCRETE WASHOUT AREA DETAIL.

CONCRETE WASHOUT AREA

NOT TO SCALE

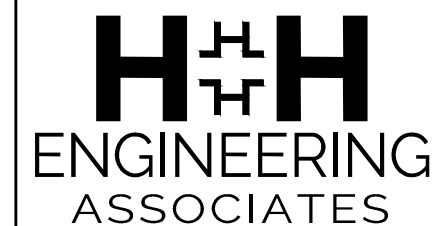

H+H ENGINEERING ASSOCIATES
 232 Greenmanville Avenue
 Suite 201
 Mystic, CT 06355
 860-980-8008 (C) 413-579-4488 (M)
 www.hh-engineers.com

STAMP

NO.	REVISIONS PER REVIEW COMMENTS	DATE	APPR.
1	REV		
2	REVISIONS PER ENGINEERING REVIEW COMMENTS & IWA COMMENTS	3/17/2023	SHM
	REVISIONS PER REVIEW COMMENTS	2/24/2023	SHM

SOIL EROSION & SEDIMENT CONTROL NARRATIVE AND DETAILS

VESSEL MULTI-FAMILY HOUSING
 PROPERTY ADDRESS
 446 HOPMEADOW STREET, SIMSBURY, CT 06089
 PREPARED FOR
VESSEL RE HOLDINGS, LLC
 46 WEST 55TH STREET, NEW YORK, NY 10019

PROJECT NO.	SCALE
2022-0013	NOT TO SCALE
DRAWN BY: SHM	DATE: 12/16/2022
CHECKED BY: SHM	DATE: 12/16/2022
DRAWING SEN-1	
SHEET NUMBER: 8 OF 13	

STAMP

SHM	3/17/2023	REVISIONS PER ENGINEERING REVIEW COMMENTS & IWA COMMENTS
SHM	2/24/2023	REVISIONS PER REVIEW COMMENTS
APPR.	DATE	DESCRIPTION OF REVISION
1	REV.	

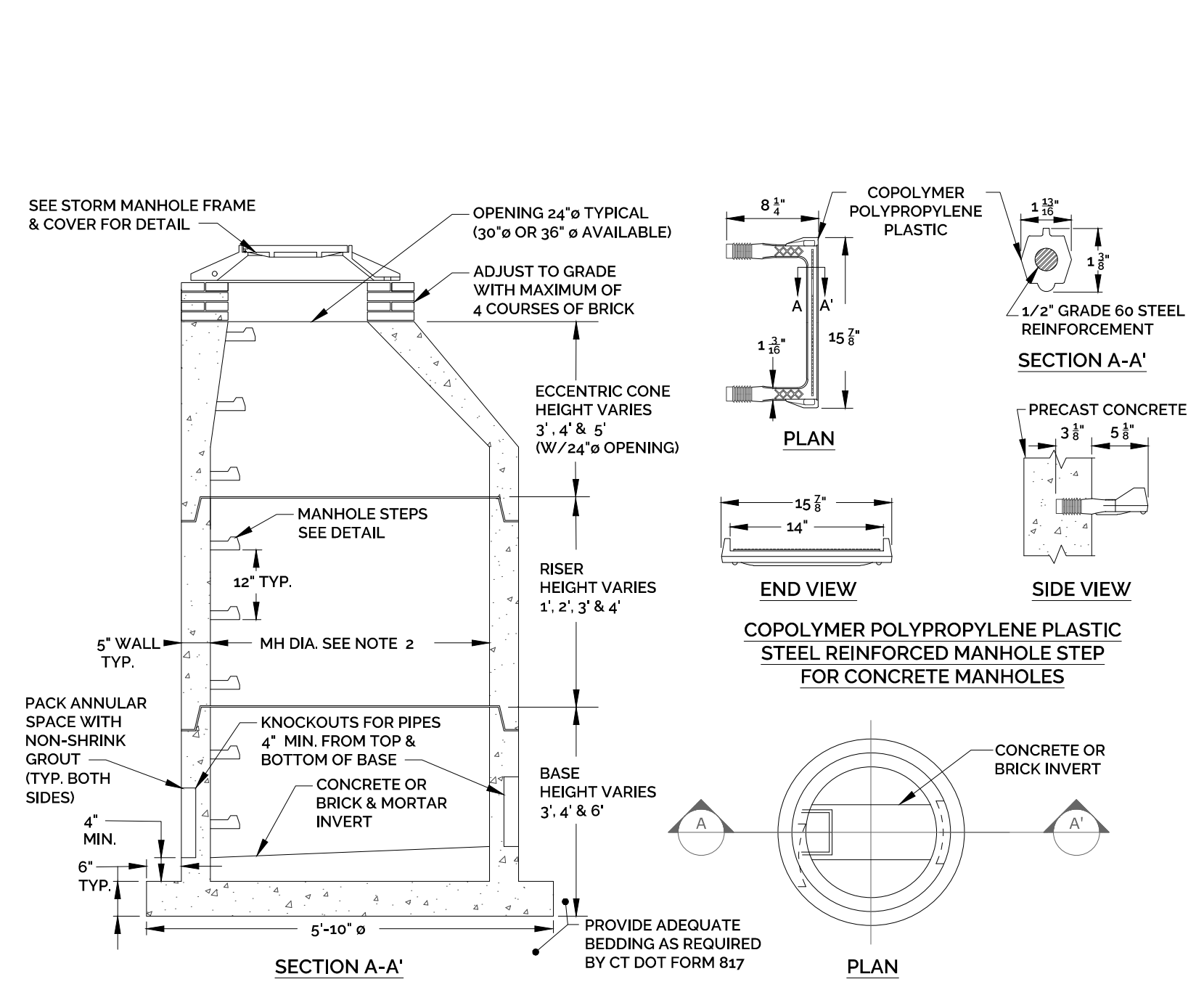

- NOTES:
1. PRECAST CONCRETE MANHOLE COMPONENTS SHALL CONFORM TO CT DOT STANDARD SHEET HW-507.10 AS AMENDED.
 2. 4", 5" OR 6" PRECAST CONCRETE BASE DIAMETERS MAY BE USED WHEN REQUIRED DUE TO SIZE OR NUMBER OF PIPES AT THE MANHOLE. PRECAST REDUCERS WILL BE PLACED ABOVE THE 5" AND 6" BASES AS DIRECTED BY THE ENGINEER. WALL THICKNESS SHALL INCREASE 1" FOR EACH 1" OF INSIDE DIAMETER INCREASE.
 3. JOINT SEALANT SHALL BE BUTYL RUBBER MASTIC TYPE SEAL THAT CONFORMS TO LATEST AASHTO SPECIFICATION M-198 & MEETS FEDERAL SPECIFICATION SS-5-0021210(A).
 4. REINFORCING STEEL DEFORMED BARS ARE NOT SHOWN AND SHALL CONFORM TO LATEST CT DOT STANDARDS & SUPPLEMENTALS AND ASTM SPECIFICATION A615, GRADE 60, MINIMUM COVER 2", UNLESS OTHERWISE NOTED.
 5. ALL PIPE OPENINGS SHALL BE CLOSED USING MATERIALS WHICH CONFORM TO STATE OF CT STANDARD SPECIFICATIONS SECTION M.08.02.
 6. REINFORCING STEEL WELDED WIRE FABRIC SHALL CONFORM TO LATEST ASTM SPECIFICATION A185.
 7. CONCRETE COMPRESSIVE STRENGTH SHALL BE MINIMUM 4000 PSI AT 28 DAYS, SELF COMPACTING CONCRETE MIX.
 8. MANHOLE STEPS SHALL MEET LATEST OSHA REGULATIONS, (29 CFR 1910.27), SECTION 16 OF ASTM SPECIFICATION C478 AND SECTION 10 OF ASTM SPECIFICATION C407.
 9. WHEN SPECIFIED, MANHOLES ARE TO BE COATED WITH BAY OIL, "EBONY".
 10. METHOD OF MANUFACTURE SHALL BE WET CAST.
 11. BASE SECTION IS MONOLITHIC.
 12. MANHOLE INTERIOR DIAMETER:
4'-0" FOR 8" TO 36" PIPE DIAMETERS
5'-0" FOR 42" PIPE DIAMETER
6'-0" FOR 48" PIPE DIAMETER.
- REFERENCE: CT DOT HIGHWAY STANDARDS, SHEET HW-507.04 & HW-507.10, CT DOT FORM 817 AND (MANHOLE STEPS) THE METROPOLITAN DISTRICT SEWER STANDARD DETAILS FIG. 5-34, DATED JAN. 2017.

STANDARD PRECAST CONCRETE STORM MANHOLE DETAIL
NOT TO SCALE

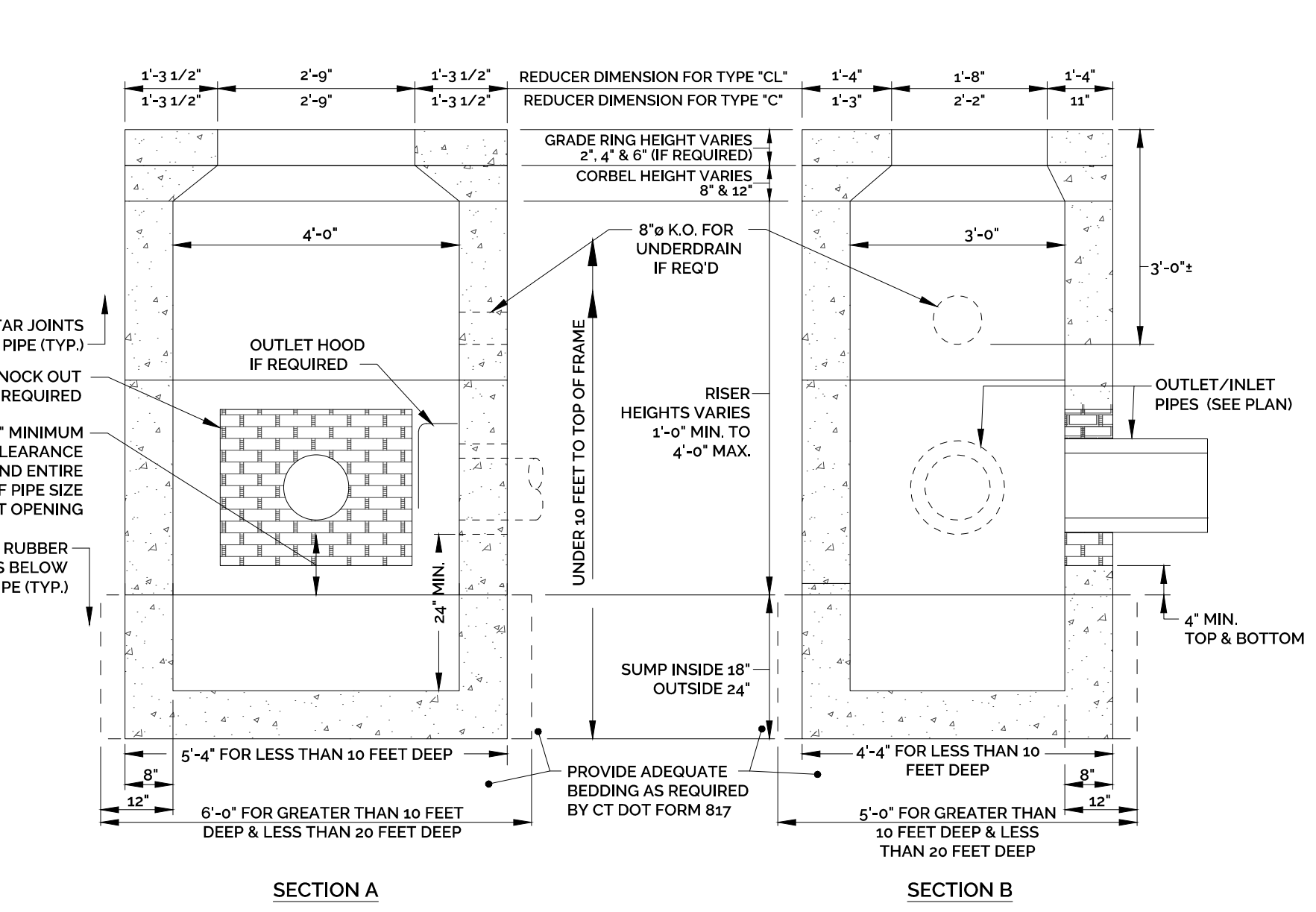
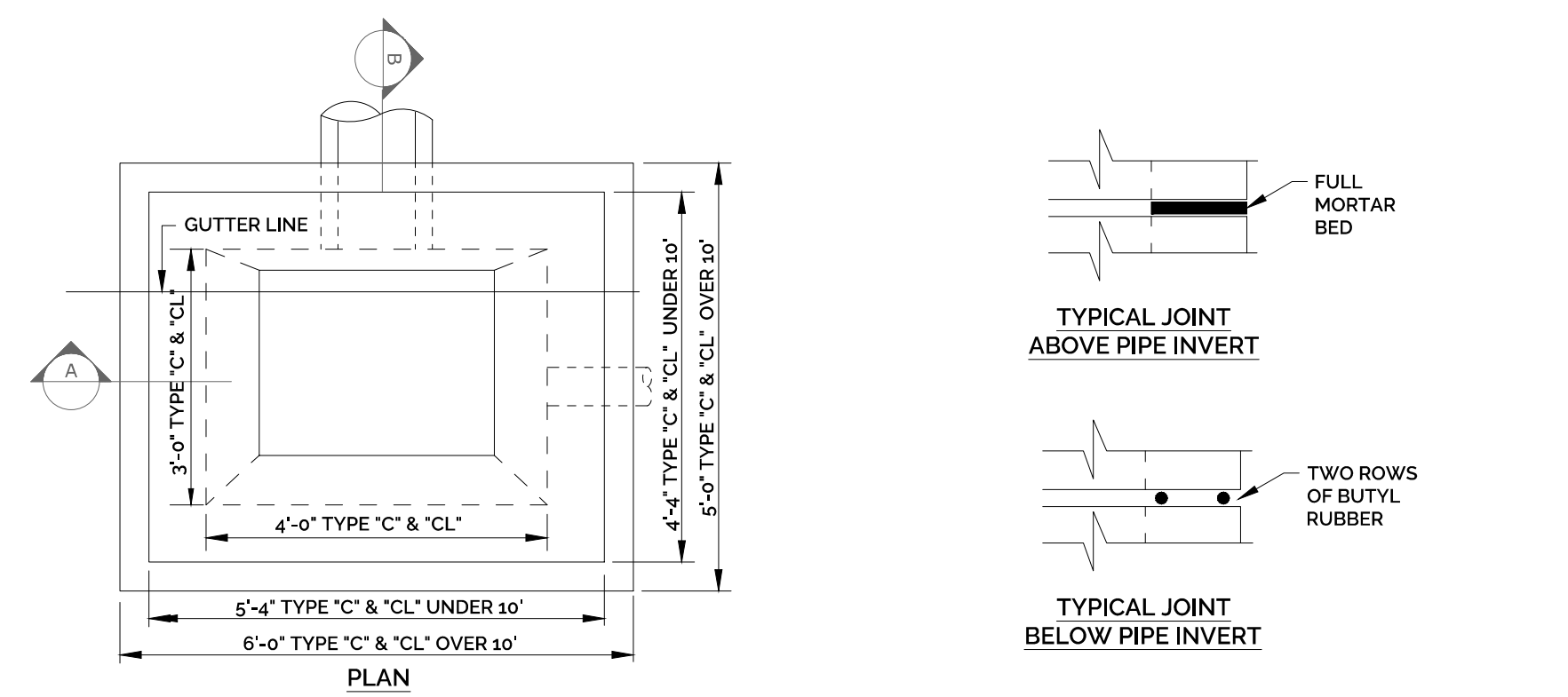

- NOTES:
1. PRECAST CONCRETE CATCH BASIN COMPONENTS SHALL CONFORM TO CT DOT FORM 817 STANDARD SPECIFICATION FOR ROADS, BRIDGES AND INCIDENTAL CONSTRUCTION AND CT DOT HIGHWAY STANDARD SHEETS HW-507.04, HW-507.07 & HW-507.08, AS AMENDED.
 2. THIS DETAIL IS BASED ON CT DOT PRECAST CONCRETE TYPE "C" & "CL" CATCH BASIN COMPONENTS, (UNDER 10' DEEP SHOWN).
 3. REINFORCING STEEL DEFORMED BARS ARE NOT SHOWN AND SHALL CONFORM TO LATEST CT DOT STANDARDS & SUPPLEMENTALS AND ASTM SPECIFICATION A615, GRADE 60, MINIMUM COVER 2" UNLESS OTHERWISE NOTED.
 4. METHOD OF MANUFACTURE SHALL BE WET CAST.
 5. SUMP SECTION SHALL BE MONOLITHIC.
 6. DESIGN LOAD SHALL BE AASHTO H-20.
- REFERENCE: CT DOT HIGHWAY STANDARDS, SHEET HW-507.04, HW-507.07 & HW-507.08, CT DOT FORM 817, AND UNITED CONCRETE PRODUCTS, AUGUST 2015

TYPE "C" AND "CL" PRECAST CONCRETE CATCH BASIN DETAILS
NOT TO SCALE

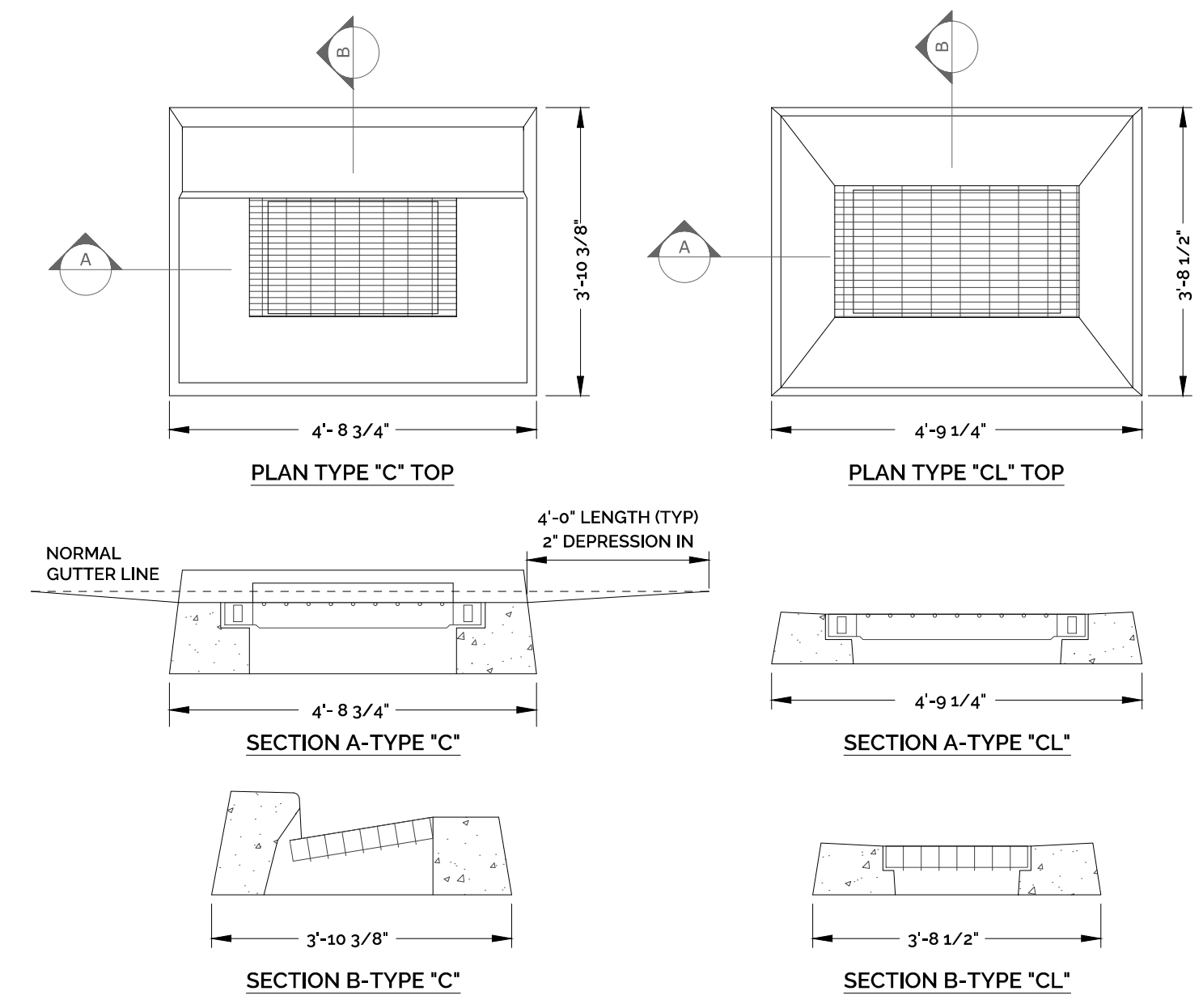

- NOTES:
1. CATCH BASIN TOPS, CURBS AND GRATE COMPONENTS SHALL CONFORM TO CT DOT FORM 817 STANDARD SPECIFICATION FOR ROADS, BRIDGES AND INCIDENTAL CONSTRUCTION AND CT DOT HIGHWAY STANDARD SHEETS HW-507.07 AND HW-507.08, AS AMENDED.
 2. REINFORCING STEEL DEFORMED BARS ARE NOT SHOWN AND SHALL CONFORM TO LATEST CT DOT STANDARDS & SUPPLEMENTALS AND ASTM SPECIFICATION A615, GRADE 60, MINIMUM COVER 2" UNLESS OTHERWISE NOTED.
 3. ALL STEEL, EXCEPT REINFORCING BARS, SHALL BE GALVANIZED IN CONFORMANCE WITH SECTION M06.03 OF CONNECTICUT STANDARD SPECIFICATIONS.
 4. TYPE "C" CATCH BASIN DEPRESSED GUTTER STRIPS SHALL CONFORM TO CT DOT STANDARD SHEET HW-507.01, AS AMENDED.
- REFERENCE: CT DOT HIGHWAY STANDARDS, SHEET HW-507.04, HW-507.07 & HW-507.08, CT DOT FORM 817, AND UNITED CONCRETE PRODUCTS, AUGUST 2015.

TYPE "C" AND "CL" CATCH BASIN TOP DETAILS
NOT TO SCALE

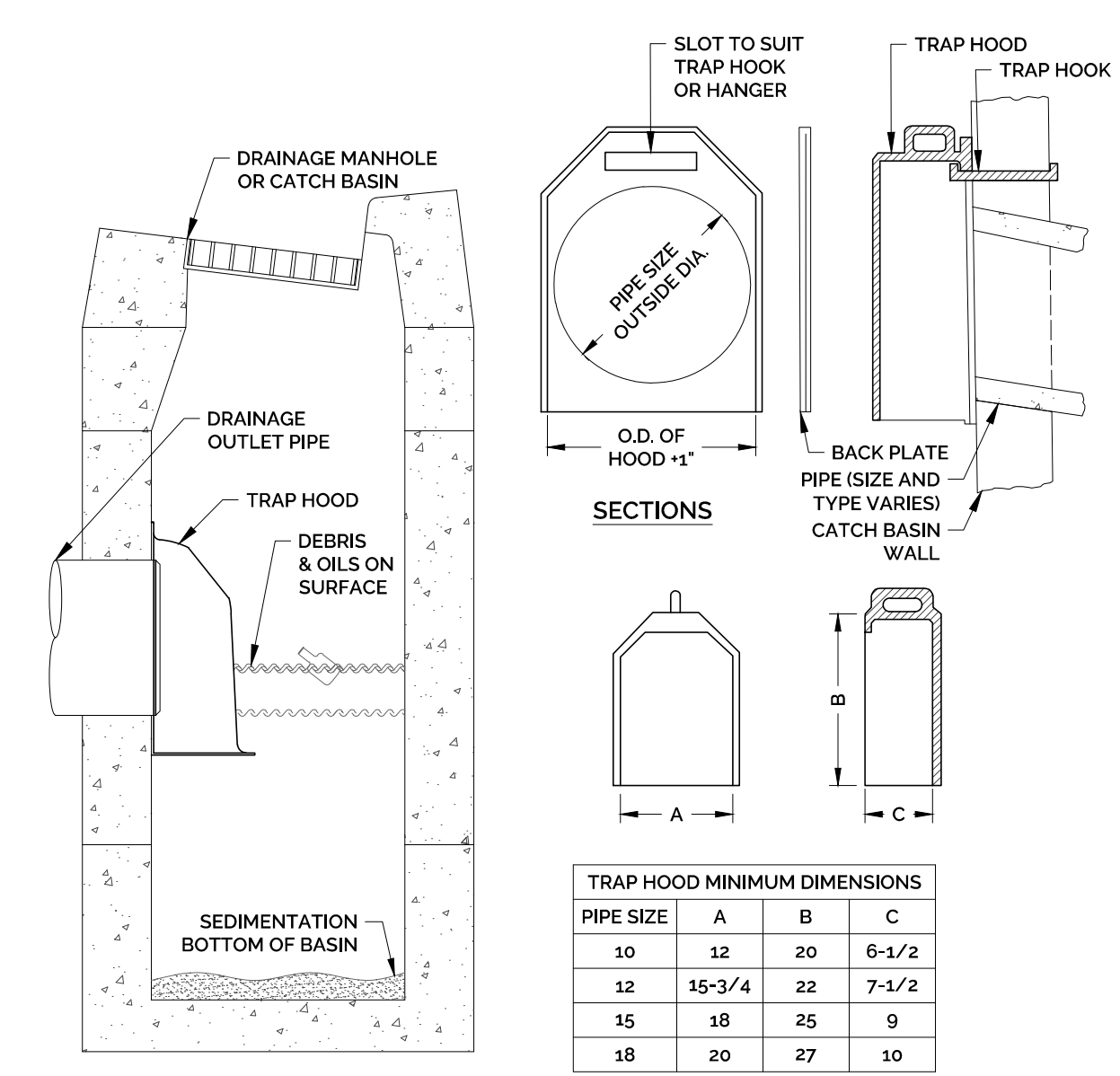

- NOTES:
1. TRAP HOODS SHALL BE CAST IRON FOR 10", 12", 15" AND 18" PIPE SIZES AND FABRICATED ALUMINUM FOR 21" OR GREATER.
 2. ALL TRAP HOODS SHALL INCLUDE STAINLESS STEEL HOOKS OR HANGERS FOR MOUNTING TO THE CATCH BASIN WALL. BACK PLATES SHALL BE FURNISHED ONLY WHEN REQUESTED.
 3. TRAP HOODS SHALL BE FROM CAMPBELL FOUNDRY, NEENAH FOUNDRY, EAST JORDAN IRON WORKS OR APPROVED EQUAL. DIMENSIONS AND MODEL NUMBERS VARY BASED ON DISCHARGE PIPE SIZE AND MANUFACTURER.
 4. SEE MANUFACTURER FOR INSTALLATION INSTRUCTIONS.

CATCH BASIN TRAP HOOD DETAIL
NOT TO SCALE

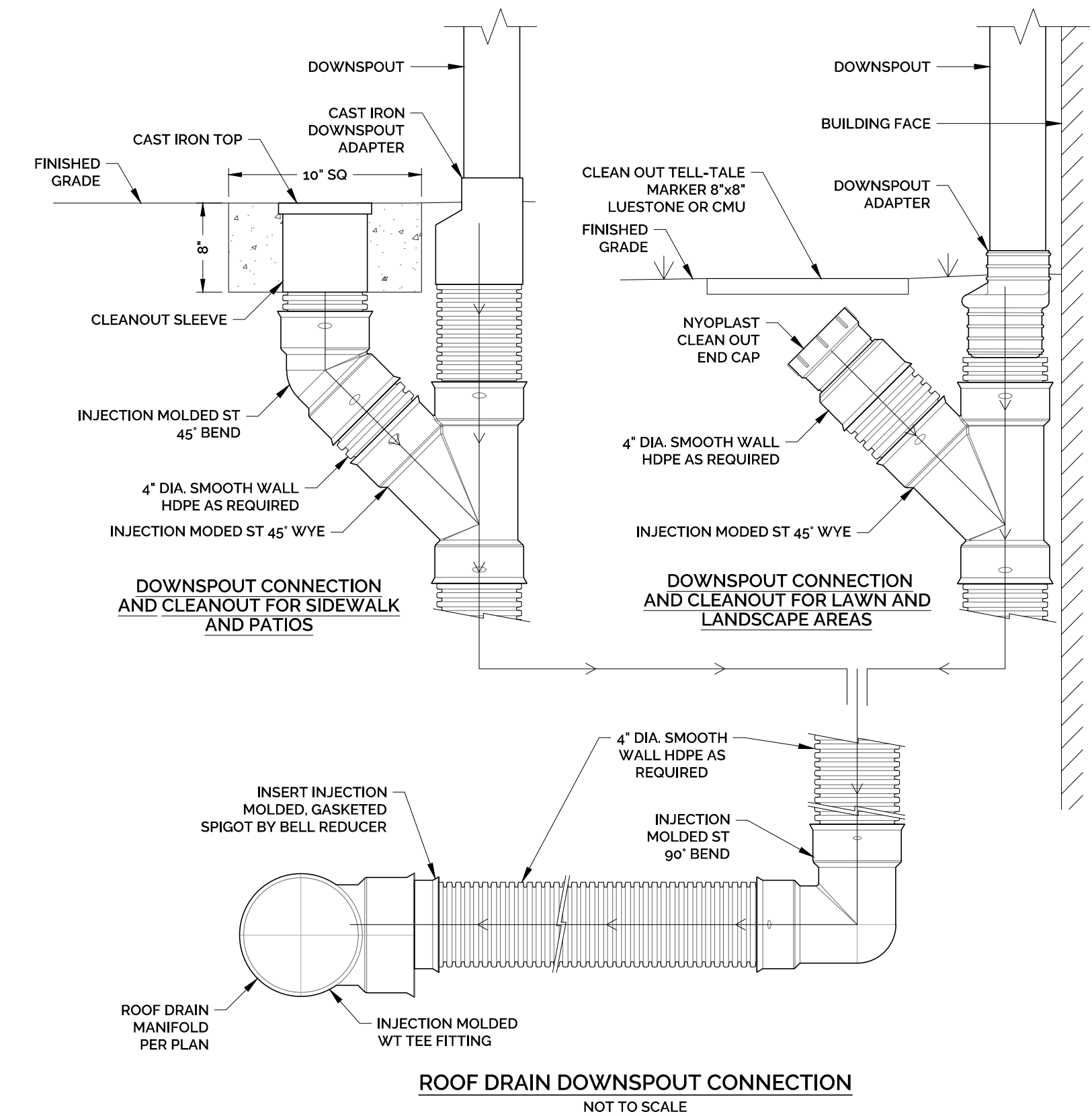

ROOF DRAIN DOWNSPOUT CONNECTION
NOT TO SCALE

DRAINAGE DETAILS

VESEL MULTI-FAMILY HOUSING
PROPERTY ADDRESS
446 HOPMEADOW STREET, SIMSBURY, CT 06089
PREPARED FOR
VESEL RE HOLDINGS, LLC
46 WEST 55TH STREET, NEW YORK, NY 10019

PROJECT NO.	SCALE
2022-0013	NOT TO SCALE
DRAWN BY:	DATE
SMM	12/16/2022
CHECKED BY:	DATE
SMM	12/16/2022

DRAWING
DT-3
SHEET NUMBER: 11 OF 13

STAMP

NO.	DATE	DESCRIPTION OF REVISION	SHM	SHM	APPR.
1	3/17/2023	REVISIONS PER ENGINEERING REVIEW COMMENTS & IWA COMMENTS			
2	2/24/2023	REVISIONS PER REVIEW COMMENTS			

UTILITY DETAILS

VESEL MULTI-FAMILY HOUSING
PROPERTY ADDRESS
446 HOPMEADOW STREET, SIMSBURY, CT 06089
PREPARED FOR
VESEL RE HOLDINGS, LLC
46 WEST 55TH STREET, NEW YORK, NY 10019

PROJECT NO.	SCALE
2022-0013	NOT TO SCALE
DRAWN BY: SMM	DATE 12/16/2022
CHECKED BY: SMM	DATE 12/16/2022
DRAWING DT-4	
SHEET NUMBER: 12 OF 13	

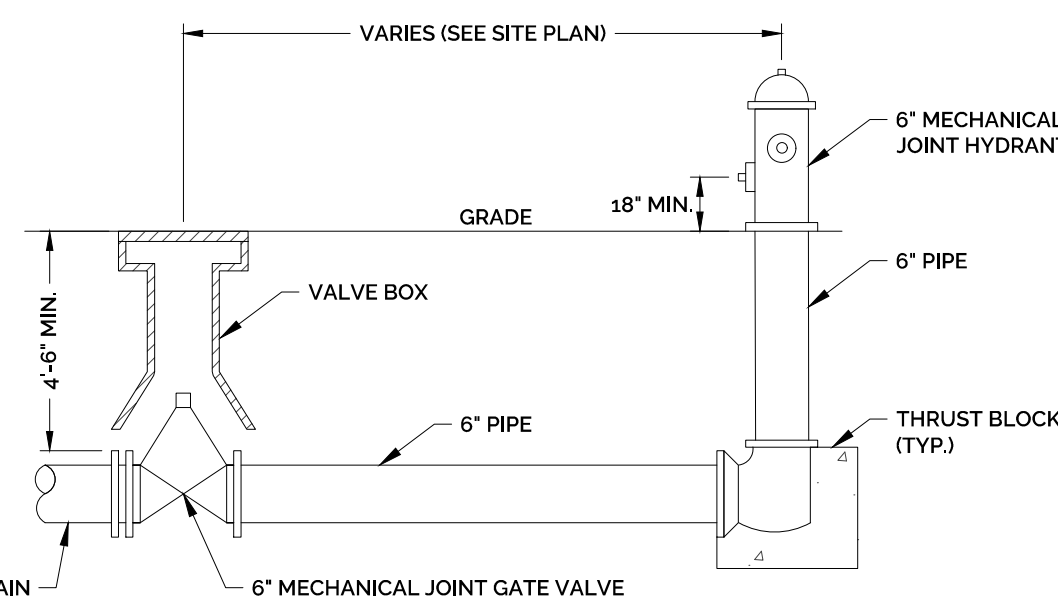

TYPICAL HYDRANT INSTALLATION
NOT TO SCALE

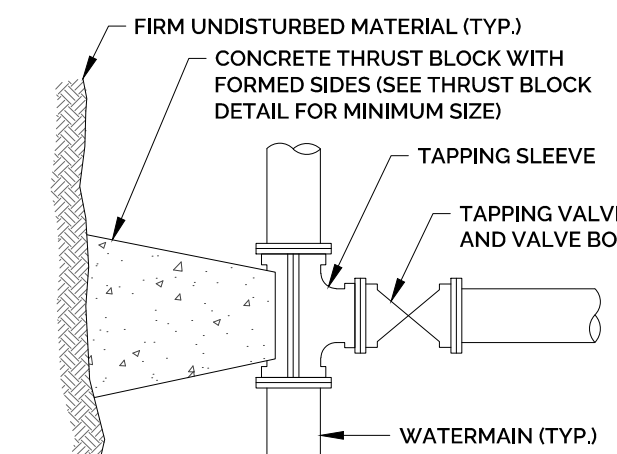

TAPPING SLEEVE & VALVE DETAIL
NOT TO SCALE

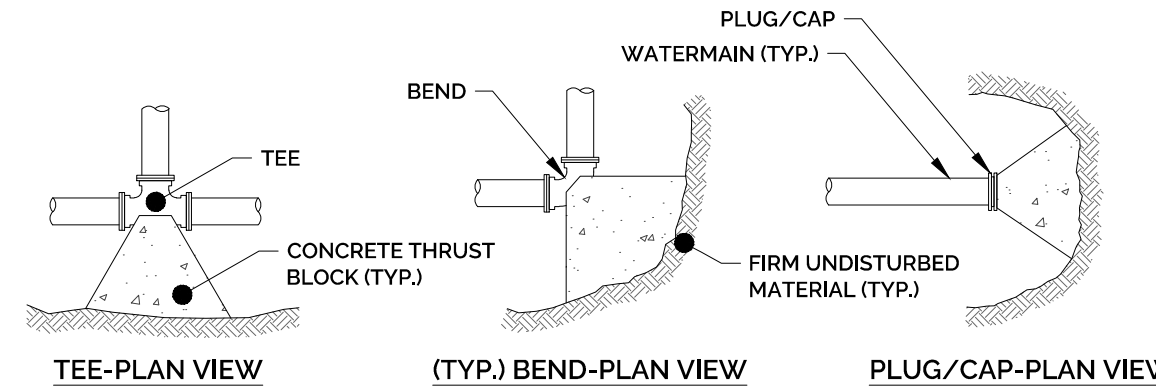

SIZE OF MAIN (IN.)	BEND (90°)	BENDS (45° & UNDER)	TEES, CAPS OR PLUGS
8 & UNDER	6	3	4
10 & 12	12	6	9

- NOTES:
- CONCRETE FOR THRUST BLOCKS SHALL HAVE A MINIMUM COMPRESSIVE STRENGTH OF 2000 PSI AT 28 DAYS.
 - THRUST BLOCK BEARING AREAS TO BE IN ACCORDANCE WITH TABLE, UNLESS DETERMINED OTHERWISE BY THE ENGINEER BECAUSE OF SOIL CONDITIONS.
 - THRUST BLOCK SIDES SHALL BE FORMED WITH PLYWOOD.

THRUST BLOCK DETAILS
NOT TO SCALE

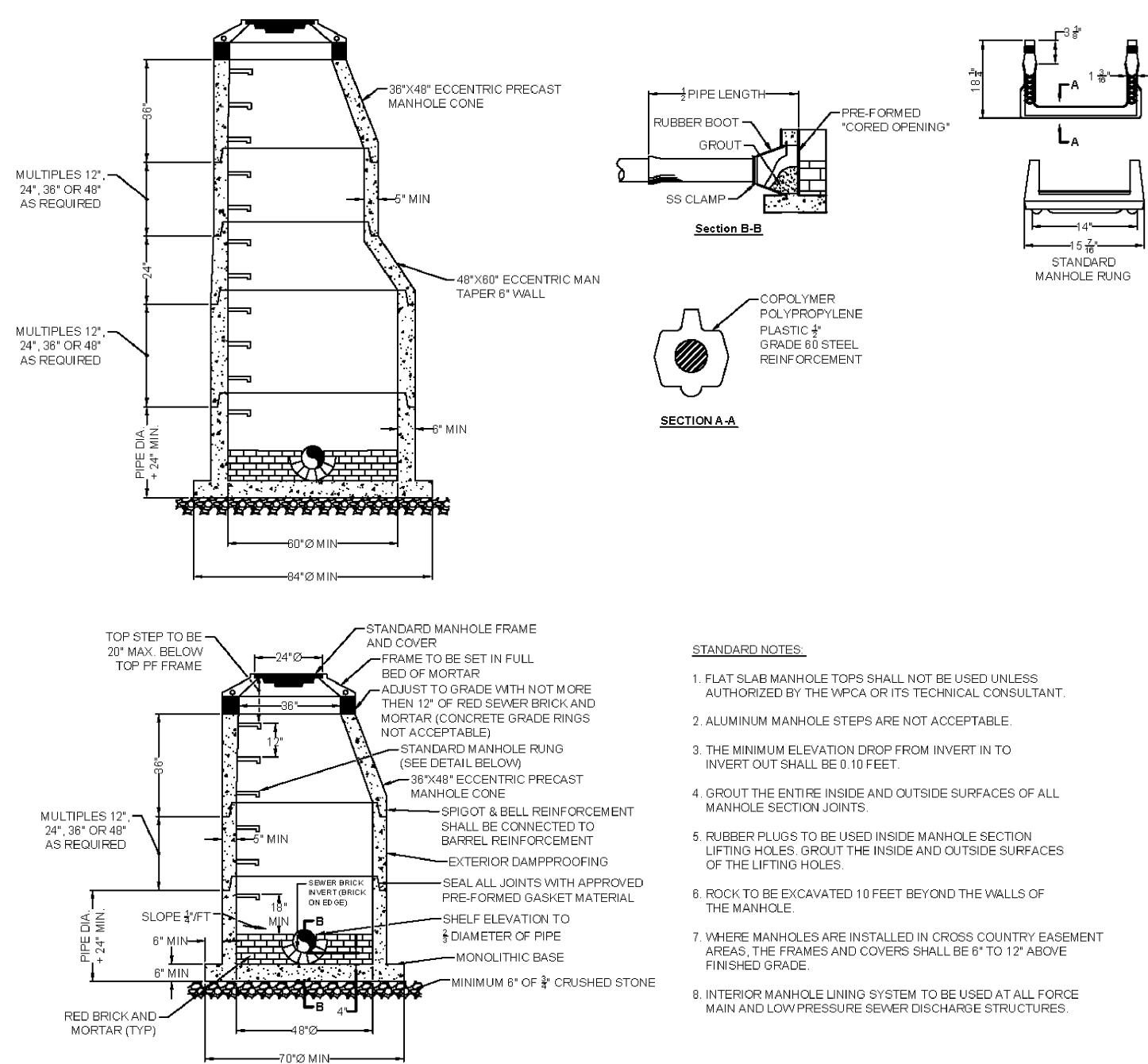

TOWN OF SIMSBURY DETAIL -
STANDARD SANITARY SEWER MANHOLE
NOT TO SCALE

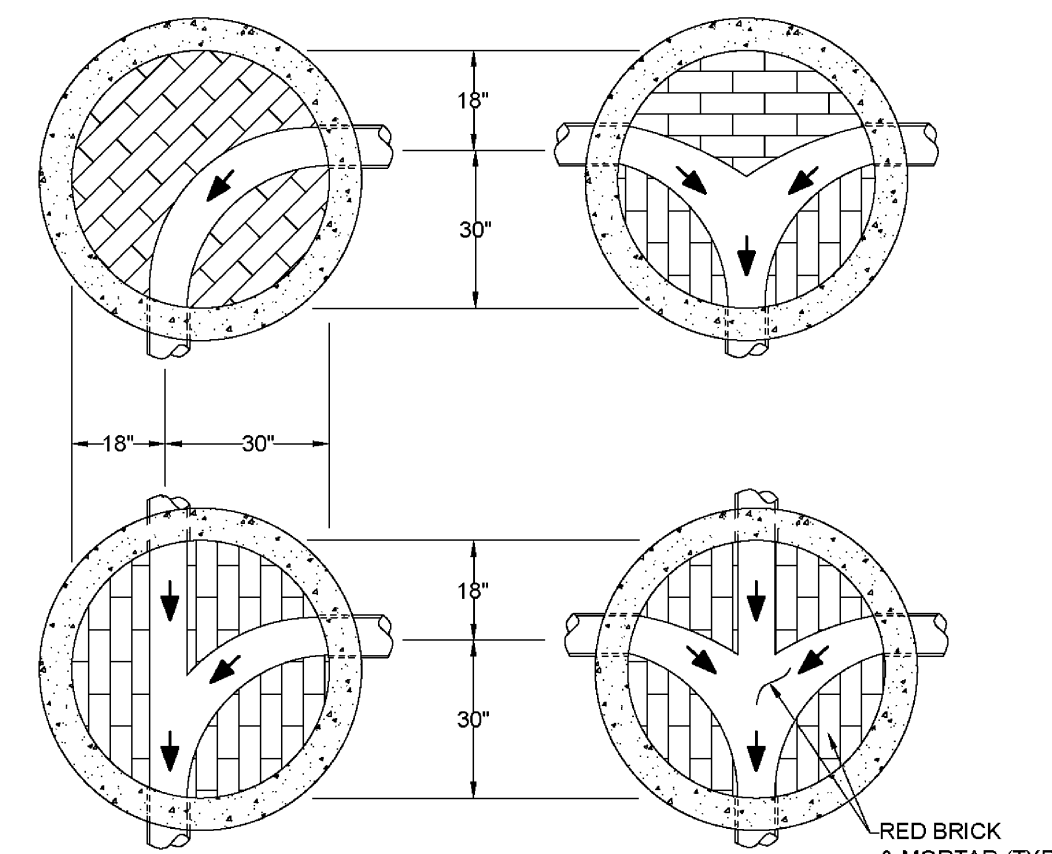

- STANDARD NOTES:
- DIMENSIONS SHOWN FOR STANDARD 48\"/>
 - MAXIMUM CHANGE IN DIRECTION FOR FLOW STREAM SHALL BE 90 DEGREES.

TOWN OF SIMSBURY DETAIL -
STANDARD MANHOLE INVERTS
NOT TO SCALE

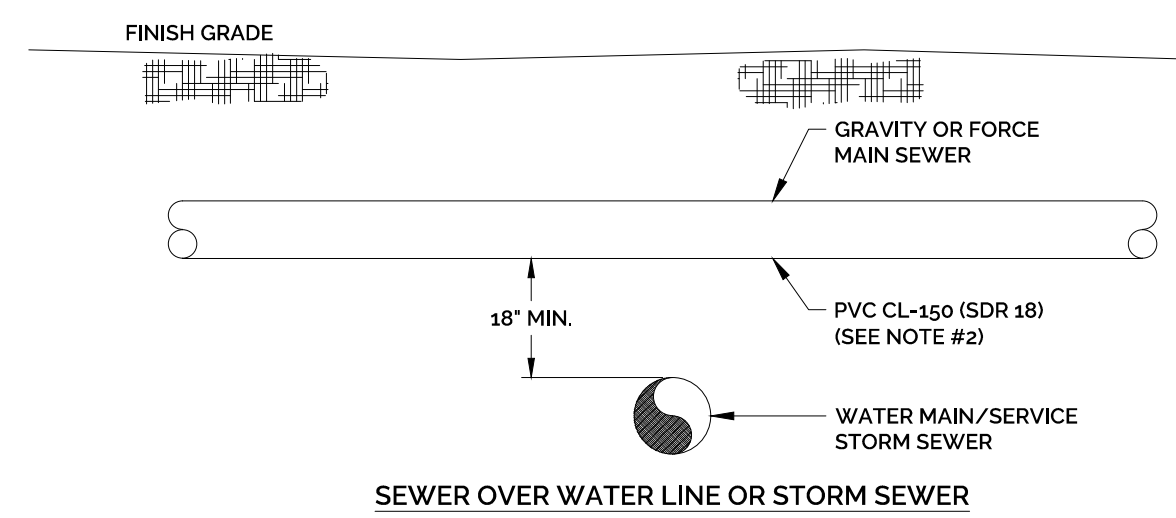

SEWER OVER WATER LINE OR STORM SEWER

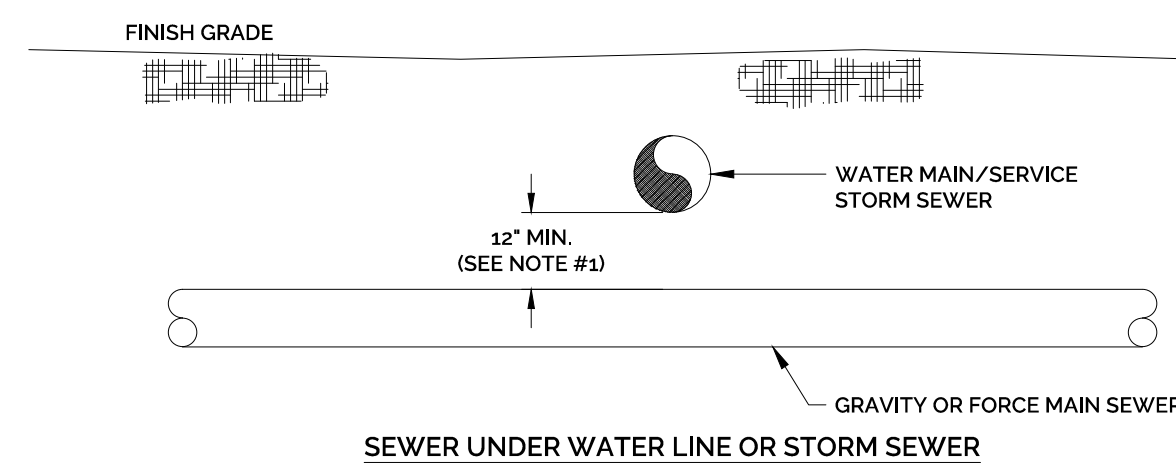

SEWER UNDER WATER LINE OR STORM SEWER

- NOTES:
- WHEN THE VERTICAL SEPARATION DISTANCE IS 12\"/>
 - THE SEWER PIPE SHALL BE PVC CL-150 (SDR 18) FOR A DISTANCE OF 10'-0\"/>
 - THESE SEPARATION DISTANCES APPLY TO ANY SEWER WITHIN A TOWN RIGHT-OF-WAY OR EASEMENT.

VERTICAL SEPARATION DISTANCES
NOT TO SCALE

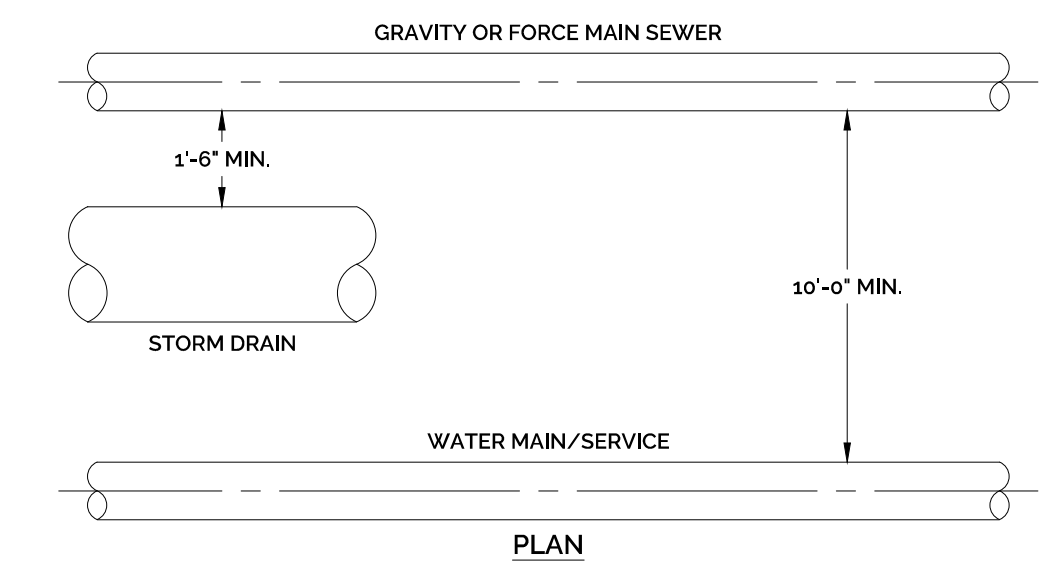

- NOTES:
- THESE SEPARATION DISTANCES APPLY TO ANY SEWER WITHIN A TOWN RIGHT-OF-WAY OR EASEMENT.
 - HORIZONTAL RESTRICTIONS FOR STORM SEWER ONLY APPLY WHEN PIPES ARE AT THE SAME ELEVATION.

HORIZONTAL SEPARATION DISTANCES
NOT TO SCALE

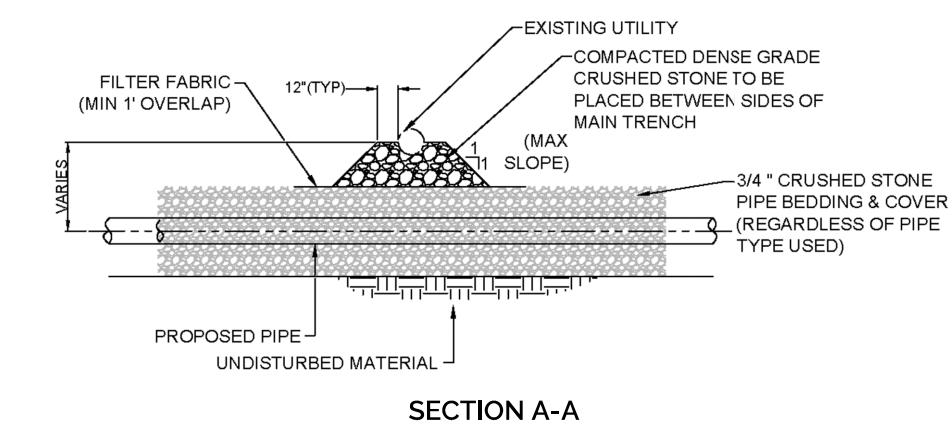

SECTION A-A

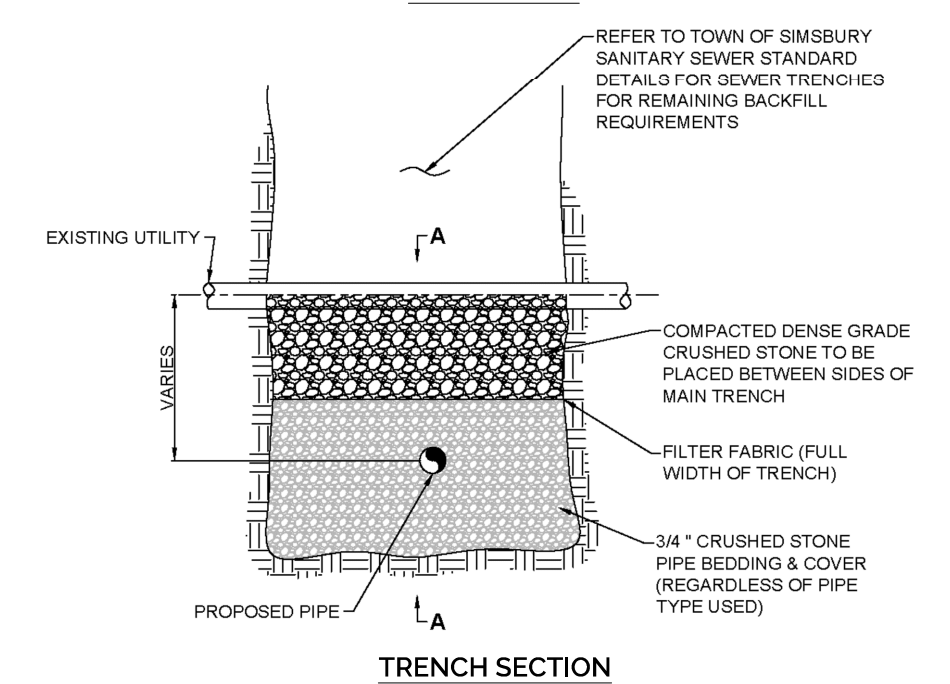

TRENCH SECTION

- STANDARD NOTES:
- PLACE 1\"/>
 - PROVIDE THE APPROPRIATE UNDERGROUND UTILITY WARNING TAPE OVER THE EXISTING UTILITY PIPE THAT HAS BEEN DISTURBED DURING INSTALLATION OF THE SANITARY SEWER. PROVIDE WARNING TAPE REGARDLESS IF EXISTING PIPE WAS NOT DISCOVERED.

TOWN OF SIMSBURY DETAIL -
PIPE SUPPORT UTILITY CROSSING
NOT TO SCALE

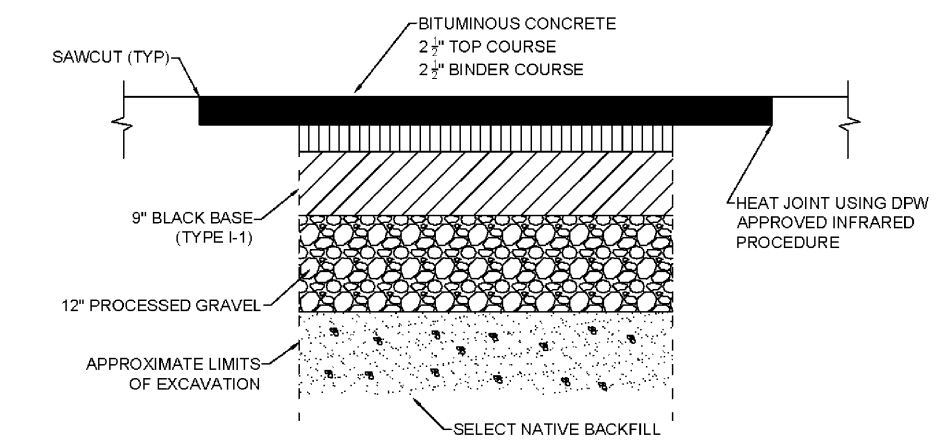

PERMANENT TRENCH REPAIR (STATE ROADS)
TOWN OF SIMSBURY DETAIL -
PERMANENT TRENCH REPAIR
NOT TO SCALE

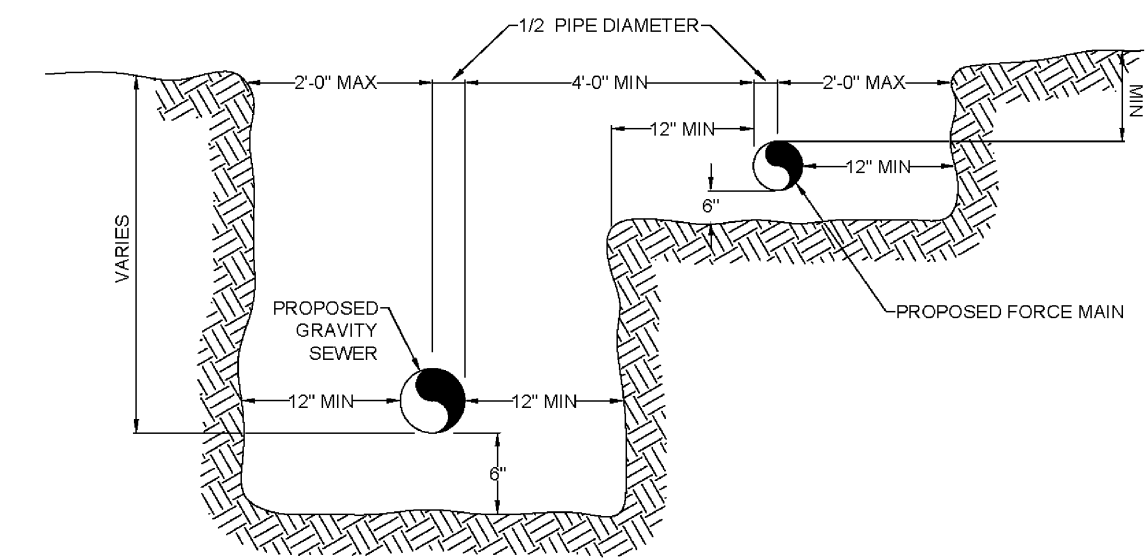

- STANDARD NOTES:
- REFER TO TOWN OF SIMSBURY SANITARY SEWER DETAILS FOR INDIVIDUAL SEWER PIPE TRENCH DETAILS.

TOWN OF SIMSBURY DETAIL -
COMMON GRAVITY SEWER & FORCE MAIN TRENCH
NOT TO SCALE

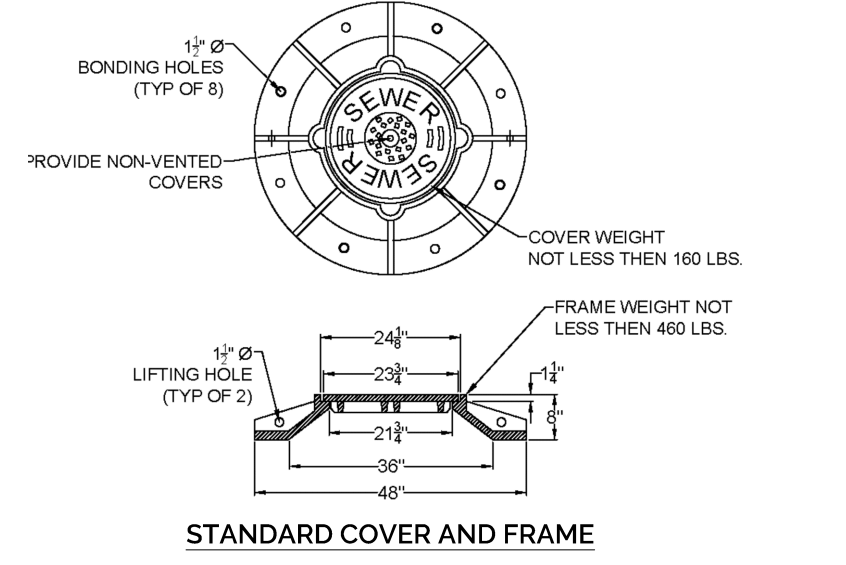

- STANDARD NOTES:
- COVER TO BE NON-VENTED, METROPOLITAN DISTRICT COMMISSION AND/OR STANDARD.
 - WATERTIGHT MANHOLE FRAMES AND COVERS SHALL ONLY BE USED AS DIRECTED BY THE WPCA OR TECHNICAL CONSULTANT. USE SHALL BE LIMITED TO ITS LOW PRESSURE SEWER AND FORCE MAIN STRUCTURES, OR IN FLOOD PLAIN AREAS.

TOWN OF SIMSBURY DETAIL -
STANDARD MANHOLE FRAME & COVER
NOT TO SCALE

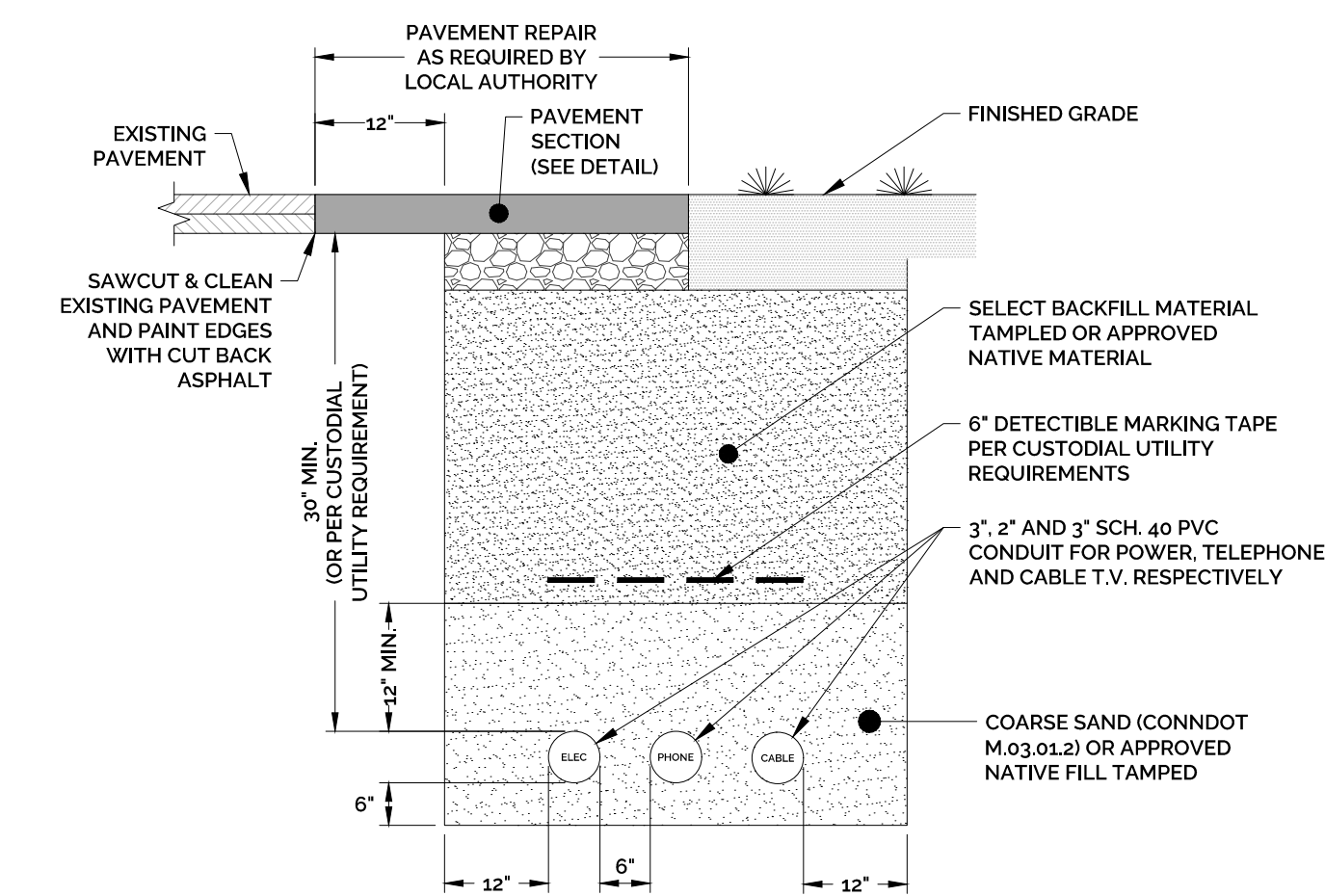

- NOTES:
- SELECT BACKFILL MATERIAL SHALL BE BANK-RUN GRAVEL GRADATION C, FORM 817, 2019, OR PROCESSED AGGREGATE CAN BE USED IN LIEU OF BANK-RUN GRAVEL OR APPROVED NATIVE MATERIAL.
 - ALL MATERIALS AND CONSTRUCTION METHODS SHALL CONFORM TO CONNECTICUT DOT STANDARD SPECIFICATIONS FOR ROADS, BRIDGES AND INCIDENTAL CONSTRUCTION FORM 817, 2019 OR AS AMENDED.
 - ALL UTILITIES SHALL BE INSTALLED IN ACCORDANCE WITH ALL MUNICIPAL AND UTILITY AUTHORITY REQUIREMENTS AND SPECIFICATIONS.
 - ALL PROPOSED MATERIALS SHALL BE INSTALLED AS SHOWN OR MATCH EXISTING CONDITIONS AS APPROVED BY THE MUNICIPALITY.
 - CONTRACTOR RESPONSIBLE FOR EXCAVATION, BEDDING, CONDUIT & BACKFILL.

TYPICAL E/T/C UTILITY TRENCH
NOT TO SCALE

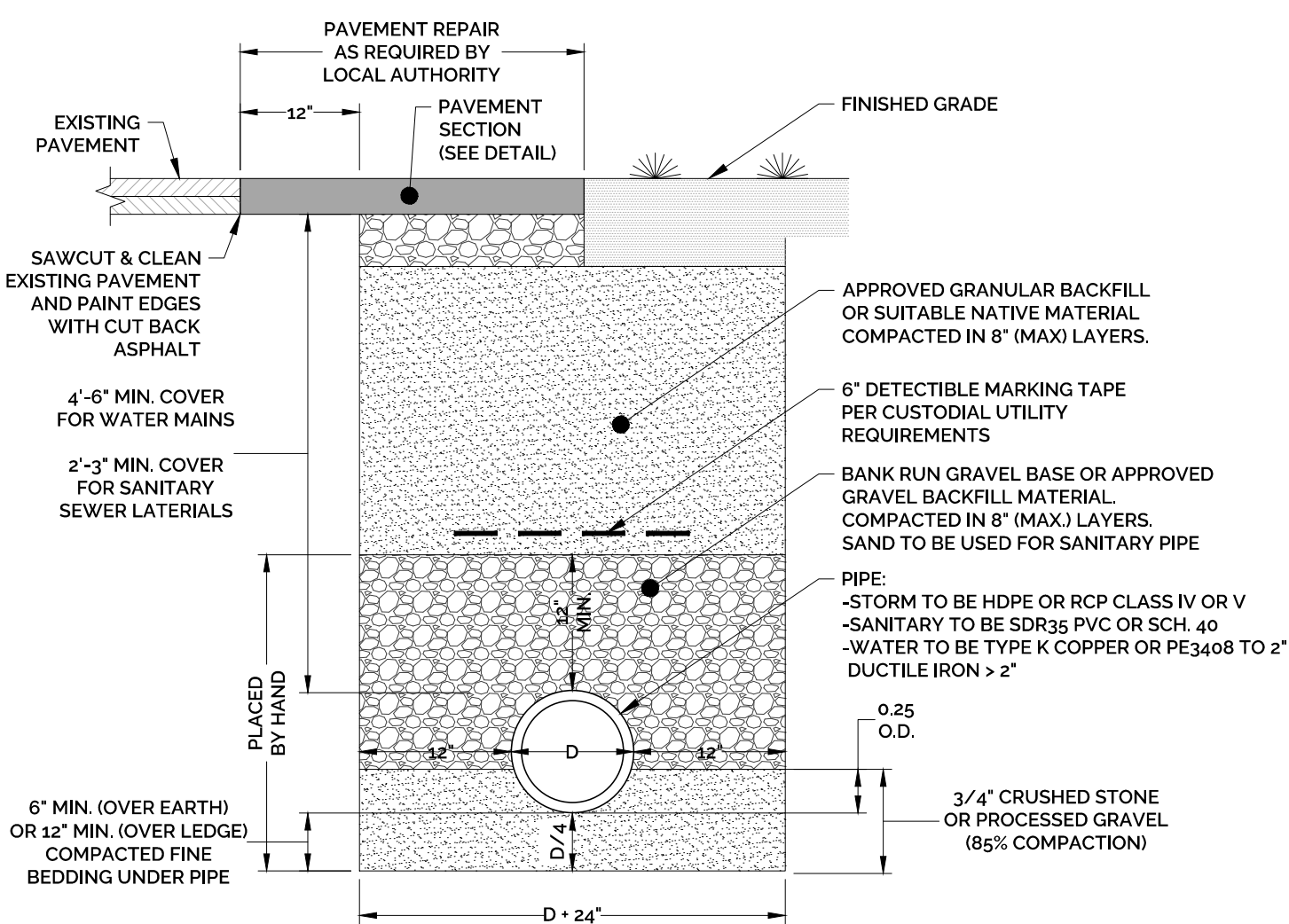

- NOTES:
- SELECT BACKFILL MATERIAL SHALL BE BANK-RUN GRAVEL GRADATION C, FORM 817, 2019, OR PROCESSED AGGREGATE CAN BE USED IN LIEU OF BANK-RUN GRAVEL OR APPROVED NATIVE MATERIAL.
 - ALL MATERIALS AND CONSTRUCTION METHODS SHALL CONFORM TO CONNECTICUT DOT STANDARD SPECIFICATIONS FOR ROADS, BRIDGES AND INCIDENTAL CONSTRUCTION FORM 817, 2019 OR AS AMENDED.
 - ALL UTILITIES SHALL BE INSTALLED IN ACCORDANCE WITH ALL MUNICIPAL AND UTILITY AUTHORITY REQUIREMENTS AND SPECIFICATIONS.
 - ALL PROPOSED MATERIALS SHALL BE INSTALLED AS SHOWN OR MATCH EXISTING CONDITIONS AS APPROVED BY THE MUNICIPALITY.
 - USE WATERTIGHT RUBBER CASSETS ASTM C443 IN ALL PIPE JOINTS.

TYPICAL TRENCH
NOT TO SCALE

ACCEPTABLE FILL MATERIALS: STORMTECH MC-3500 CHAMBER SYSTEMS

MATERIAL LOCATION	DESCRIPTION	AASHTO MATERIAL CLASSIFICATIONS	COMPACTION / DENSITY REQUIREMENT
D	FINAL FILL: FILL MATERIAL FOR LAYER 'D' STARTS FROM THE TOP OF THE 'C' LAYER TO THE BOTTOM OF FLEXIBLE PAVEMENT OR UNPAVED FINISHED GRADE ABOVE. NOTE THAT PAVEMENT SUBBASE MAY BE PART OF THE 'D' LAYER.	N/A	PREPARE PER SITE DESIGN ENGINEER'S PLANS. PAVED INSTALLATIONS MAY HAVE STRINGENT MATERIAL AND PREPARATION REQUIREMENTS.
C	INITIAL FILL: FILL MATERIAL FOR LAYER 'C' STARTS FROM THE TOP OF THE EMBEDMENT STONE ('B' LAYER) TO 24" (600 mm) ABOVE THE TOP OF THE CHAMBER. NOTE THAT PAVEMENT SUBBASE MAY BE PART OF THE 'C' LAYER.	AASHTO M145 ¹ A-1, A-2, A-3 OR AASHTO M43 ¹ 3.357, 4.467, 5.65, 57.6, 67.8, 7.8, 8.8, 9.9, 10	BEGIN COMPACTIONS AFTER 24" (600 mm) OF MATERIAL OVER THE CHAMBERS IS REACHED. COMPACT ADDITIONAL LAYERS IN 12" (300 mm) MAX LIFTS TO A MIN. 90% PROCTOR DENSITY FOR WELL GRADED MATERIAL AND 95% RELATIVE DENSITY FOR PROCESSED AGGREGATE MATERIALS.
B	EMBEDMENT STONE: FILL SURROUNDING THE CHAMBERS FROM THE FOUNDATION STONE ('A' LAYER) TO THE 'C' LAYER ABOVE.	AASHTO M43 ¹ 3.4	NO COMPACTION REQUIRED.
A	FOUNDATION STONE: FILL BELOW CHAMBERS FROM THE SUBGRADE UP TO THE FOOT (BOTTOM) OF THE CHAMBER.	AASHTO M43 ¹ 3.4	PLATE COMPACT OR ROLL TO ACHIEVE A FLAT SURFACE ^{1,3}

- PLEASE NOTE:
- THE LISTED AASHTO DESIGNATIONS ARE FOR GRADATIONS ONLY. THE STONE MUST ALSO BE CLEAN, CRUSHED, ANGULAR. FOR EXAMPLE, A SPECIFICATION FOR #4 STONE WOULD STATE: "CLEAN, CRUSHED, ANGULAR NO. 4 (AASHTO M43) STONE".
 - STORMTECH COMPACTION REQUIREMENTS ARE MET FOR 'A' LOCATION MATERIALS WHEN PLACED AND COMPACTED IN 9" (230 mm) MAX LIFTS USING TWO FULL COVERAGES WITH A VIBRATORY COMPACTOR.
 - WHERE INFILTRATION SURFACES MAY BE COMPROMISED BY COMPACTION, FOR STANDARD DESIGN LOAD CONDITIONS, A FLAT SURFACE MAY BE ACHIEVED BY RAKING OR DRAGGING WITHOUT COMPACTION EQUIPMENT. FOR SPECIAL LOAD DESIGNS, CONTACT STORMTECH FOR COMPACTION REQUIREMENTS.
 - ONCE LAYER 'C' IS PLACED, ANY SOIL/MATERIAL CAN BE PLACED IN LAYER 'D' UP TO THE FINISHED GRADE. MOST PAVEMENT SUBBASE SOILS CAN BE USED TO REPLACE THE MATERIAL REQUIREMENTS OF LAYER 'C' OR 'D' AT THE SITE DESIGN ENGINEER'S DISCRETION.

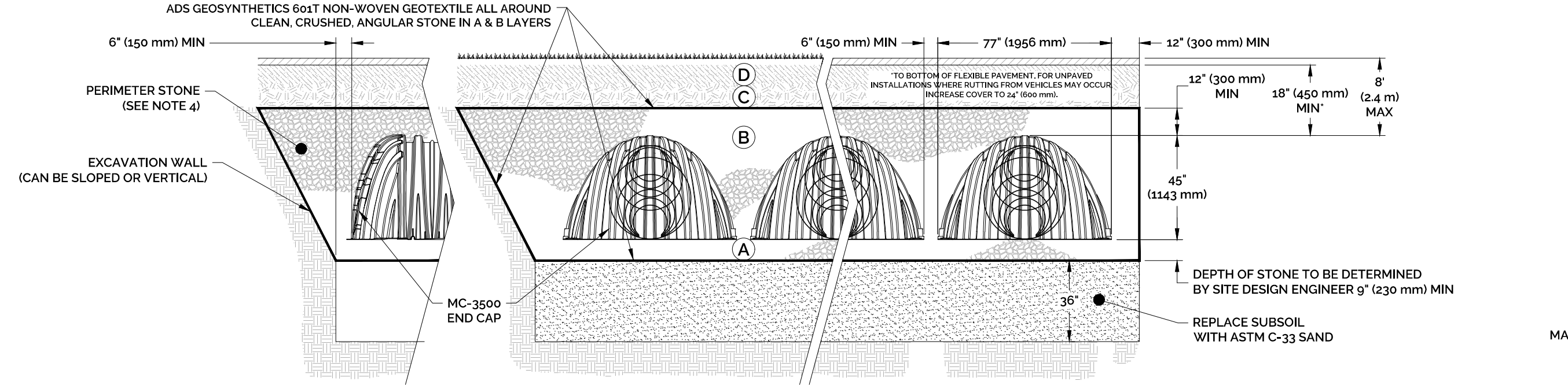

NOTES:

- CHAMBERS SHALL MEET THE REQUIREMENTS OF ASTM F2418, "STANDARD SPECIFICATION FOR POLYPROPYLENE (PP) CORRUGATED WALL STORMWATER COLLECTION CHAMBERS" CHAMBER CLASSIFICATION 45x76 DESIGNATION SS.
- MC-3500 CHAMBERS SHALL BE DESIGNED IN ACCORDANCE WITH ASTM F2787 "STANDARD PRACTICE FOR STRUCTURAL DESIGN OF THERMOPLASTIC CORRUGATED WALL STORMWATER COLLECTION CHAMBERS".
- PERIMETER STONE MUST BE EXTENDED HORIZONTALLY TO THE EXCAVATION WALL FOR BOTH VERTICAL AND SLOPED EXCAVATION WALLS.
- REQUIREMENTS FOR HANDLING AND INSTALLATION:
 - TO MAINTAIN THE WIDTH OF CHAMBERS DURING SHIPPING AND HANDLING, CHAMBERS SHALL HAVE INTEGRAL, INTERLOCKING STACKING LUGS.
 - TO ENSURE A SECURE JOINT DURING INSTALLATION AND BACKFILL, THE HEIGHT OF THE CHAMBER JOINT SHALL NOT BE LESS THAN 3".
 - TO ENSURE THE INTEGRITY OF THE ARCH SHAPE DURING INSTALLATION, THE ARCH STIFFNESS CONSTANT AS DEFINED IN SECTION 6.2.8 OF ASTM F2418 SHALL BE GREATER THAN OR EQUAL TO 500 LBS/FT²/IN. AND b) TO RESIST CHAMBER DEFORMATION DURING INSTALLATION AT ELEVATED TEMPERATURES (ABOVE 73° F / 23° C), CHAMBERS SHALL BE PRODUCED FROM REFLECTIVE GOLD OR YELLOW COLORS.

ADS STORMTECH MC-3500 CROSS SECTION DETAIL
NOT TO SCALE

INSPECTION & MAINTENANCE

- STEP 1) INSPECT ISOLATOR ROW PLUS FOR SEDIMENT
- INSPECTION PORTS (IF PRESENT)
 - REMOVE/OPEN LID ON NYLOPLAST INLINE DRAIN
 - REMOVE AND CLEAN FLEXSTORM FILTER IF INSTALLED
 - USING A FLASHLIGHT AND STEADY HAND, MEASURE DEPTH OF SEDIMENT AND RECORD ON MAINTENANCE LOG
 - LOWER A CAMERA INTO ISOLATOR ROW PLUS FOR VISUAL INSPECTION OF SEDIMENT LEVELS (OPTIONAL)
 - IF SEDIMENT IS AT OR ABOVE, 3" (80 mm) PROCEED TO STEP 2. IF NOT, PROCEED TO STEP 3.
- STEP 2) ALL ISOLATOR ROW PLUS
- REMOVE COVER FROM STRUCTURE AT UPSTREAM END OF ISOLATOR ROW PLUS
 - USING A FLASHLIGHT, INSPECT DOWN THE ISOLATOR ROW PLUS THROUGH OUTLET PIPE
 - MIRRORS ON POLES OR CAMERAS MAY BE USED TO AVOID A CONFINED SPACE ENTRY
 - FOLLOW OSHA REGULATIONS FOR CONFINED SPACE ENTRY IF ENTERING MANHOLE
 - IF SEDIMENT IS AT OR ABOVE, 3" (80 mm) PROCEED TO STEP 2. IF NOT, PROCEED TO STEP 3.
- STEP 3) CLEAN OUT ISOLATOR ROW PLUS USING THE JETVAC PROCESS
- A FIXED CULVERT CLEANING NOZZLE WITH REAR FACING SPREAD OF 45° (11.3 m) OR MORE IS PREFERRED
 - APPLY MULTIPLE PASSES OF JETVAC UNTIL BACKFLUSH WATER IS CLEAN
 - VACUUM STRUCTURE SUMP AS REQUIRED
 - REPLACE ALL COVERS, GRATES, FILTERS, AND LIDS; RECORD OBSERVATIONS AND ACTIONS.
- STEP 4) INSPECT AND CLEAN BASINS AND MANHOLES UPSTREAM OF THE STORMTECH SYSTEM.

NOTES

- INSPECT EVERY 6 MONTHS DURING THE FIRST YEAR OF OPERATION. ADJUST THE INSPECTION INTERVAL BASED ON PREVIOUS OBSERVATIONS OF SEDIMENT ACCUMULATION AND HIGH WATER ELEVATIONS.
- CONDUCT JETTING AND VACTORING ANNUALLY OR WHEN INSPECTION SHOWS THAT MAINTENANCE IS NECESSARY.

ADS STORMTECH MC-3500 ISOLATOR ROW PLUS DETAIL
NOT TO SCALE

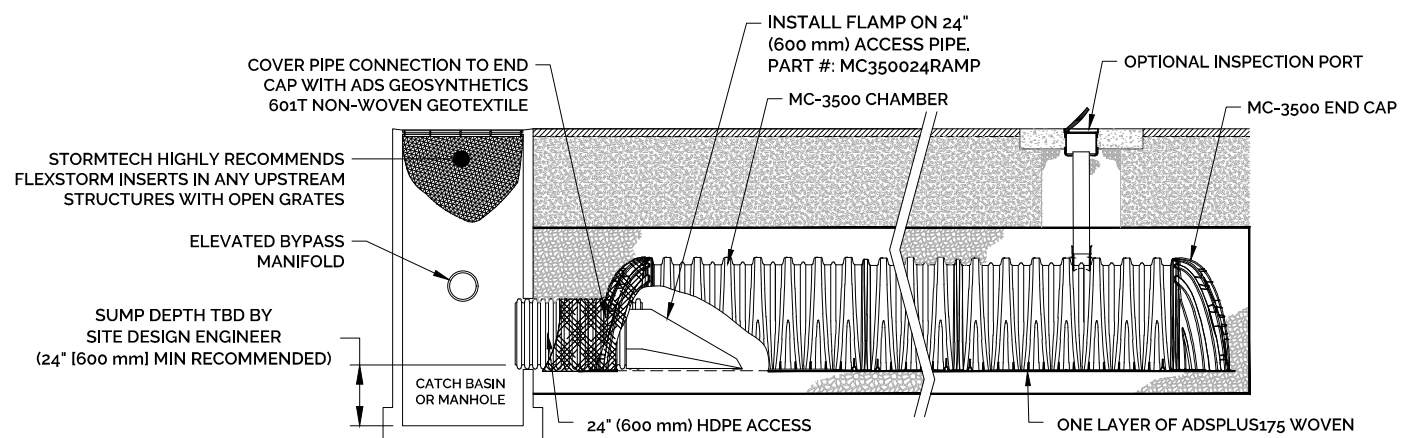

NOTES

- INSPECT EVERY 6 MONTHS DURING THE FIRST YEAR OF OPERATION. ADJUST THE INSPECTION INTERVAL BASED ON PREVIOUS OBSERVATIONS OF SEDIMENT ACCUMULATION AND HIGH WATER ELEVATIONS.
- CONDUCT JETTING AND VACTORING ANNUALLY OR WHEN INSPECTION SHOWS THAT MAINTENANCE IS NECESSARY.

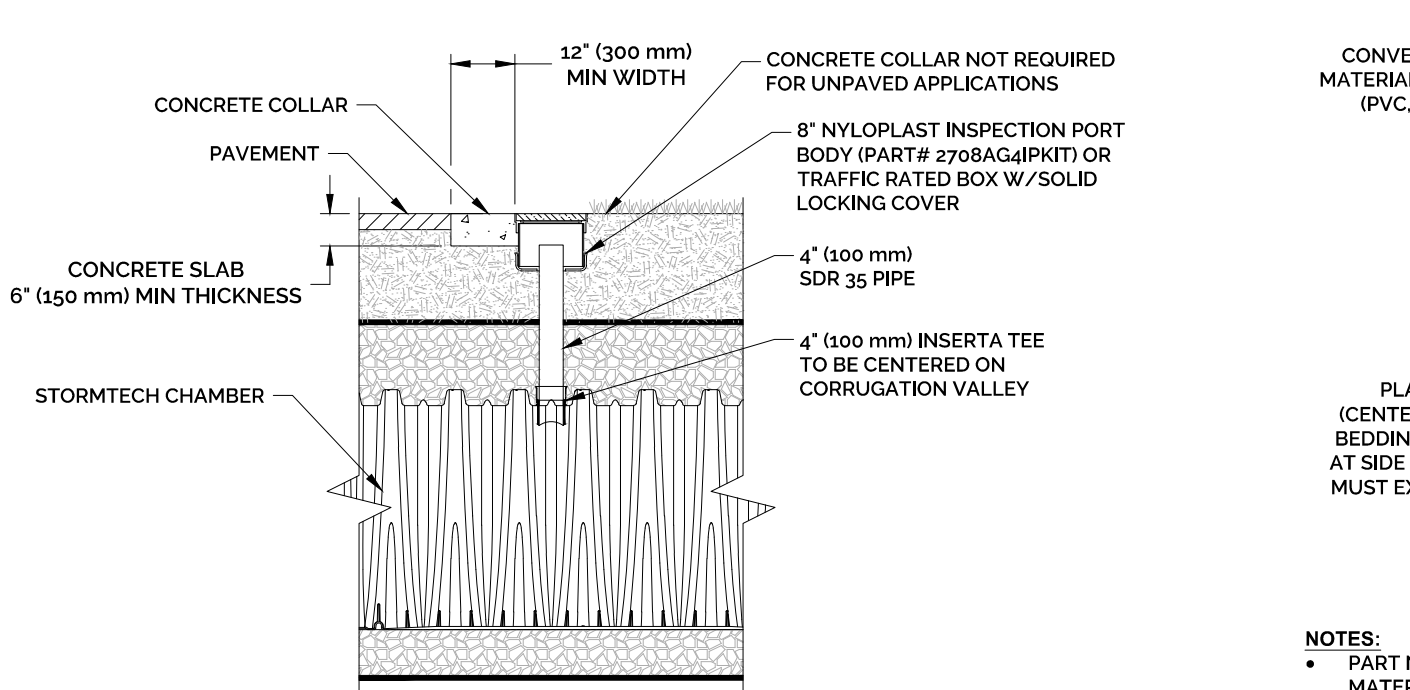

4\"/>

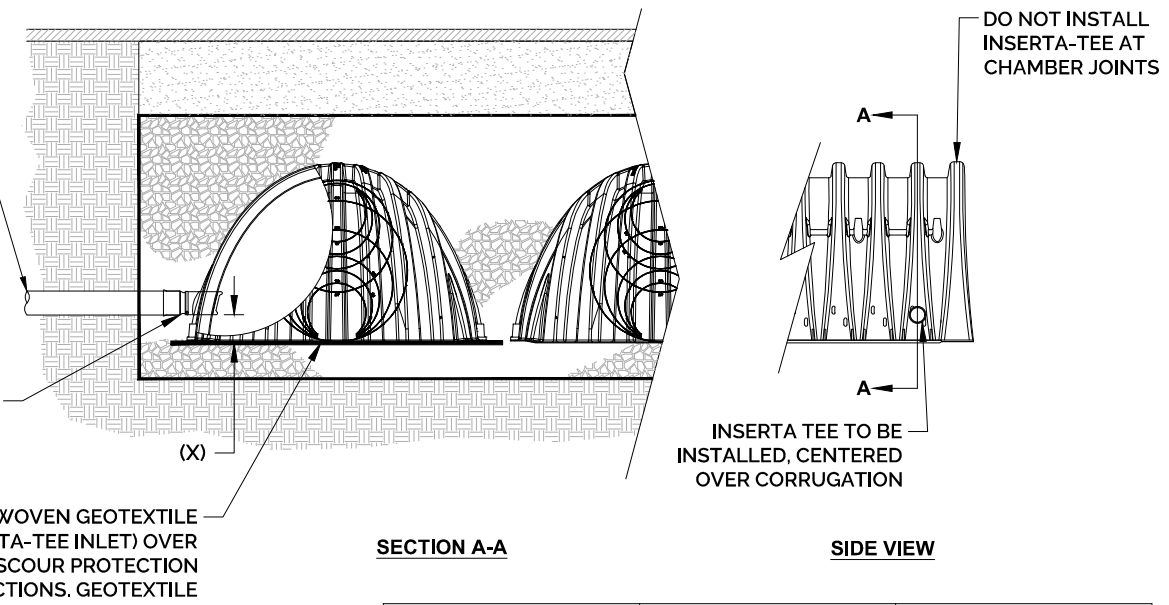

NOTES:

- PART NUMBERS WILL VARY BASED ON INLET PIPE MATERIALS. CONTACT STORMTECH FOR MORE INFORMATION.
- CONTACT ADS ENGINEERING SERVICES IF INSERTA TEE INLET MUST BE RAISED AS NOT ALL INVERTS ARE POSSIBLE.

ADS STORMTECH INSERTA-TEE SIDE VIEW DETAIL
NOT TO SCALE

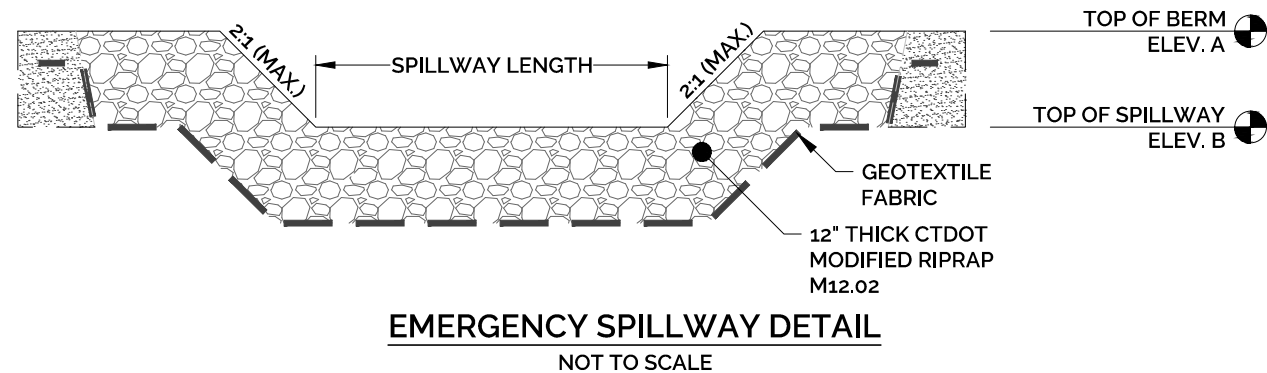

EMERGENCY SPILLWAY DETAIL
NOT TO SCALE

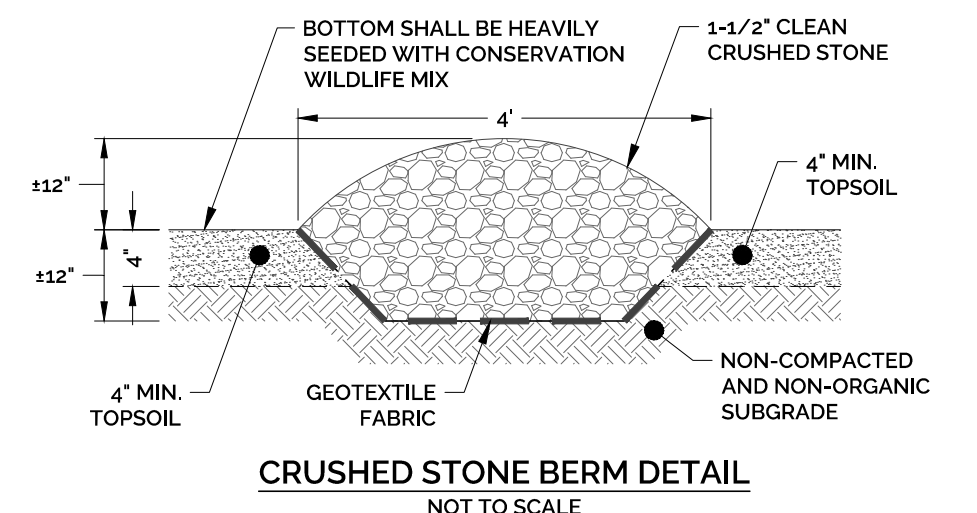

CRUSHED STONE BERM DETAIL
NOT TO SCALE

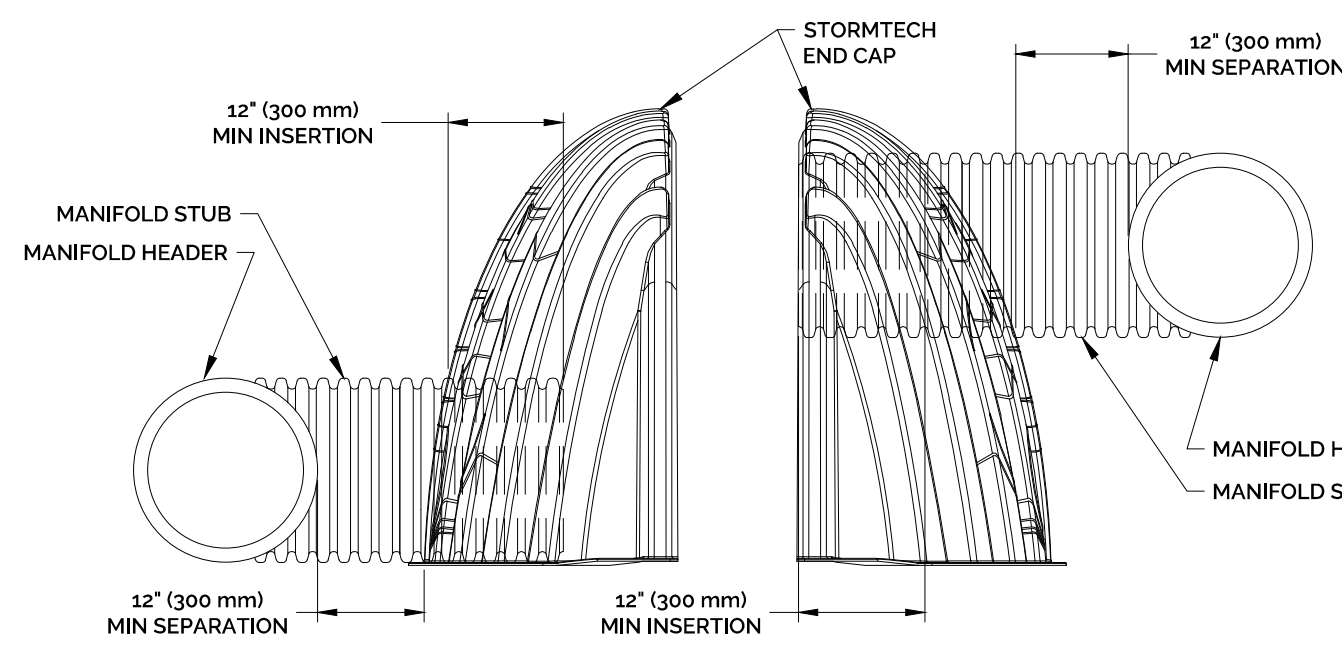

ADS STORMTECH MC-3500 END CAP INSERTION DETAIL
NOT TO SCALE

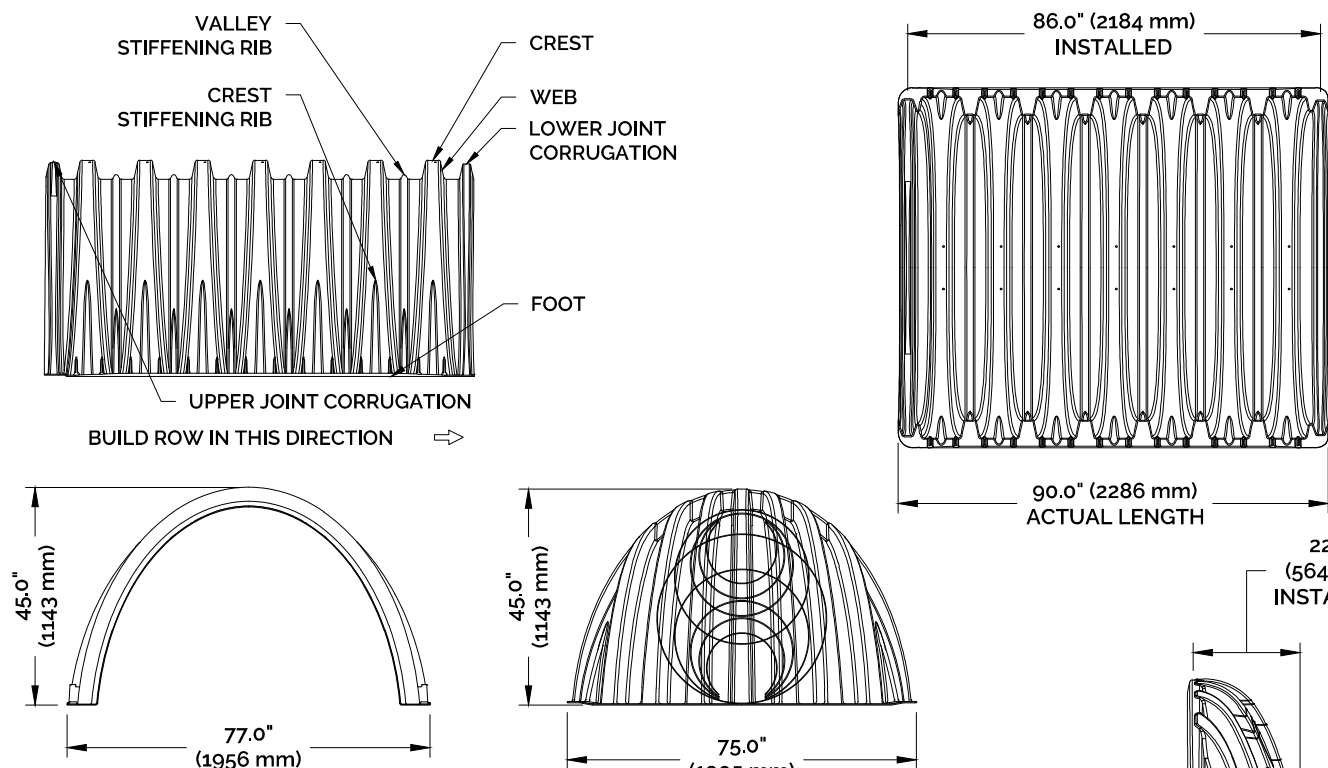

NOMINAL CHAMBER SPECIFICATIONS

SIZE (W X H X INSTALLED LENGTH)
CHAMBER STORAGE
MINIMUM INSTALLED STORAGE¹
WEIGHT

77.0" X 45.0" X 86.0" (1956 mm X 1143 mm X 2184 mm)
175.0 CUBIC FEET (4.96 m³)
134 lbs. (60.8 kg)

NOMINAL END CAP SPECIFICATIONS

SIZE (W X H X INSTALLED LENGTH)
END CAP STORAGE
MINIMUM INSTALLED STORAGE¹
WEIGHT

75.0" X 45.0" X 22.2" (1905 mm X 1143 mm X 564 mm)
14.9 CUBIC FEET (0.42 m³)
45.1 CUBIC FEET (1.28 m³)
49 lbs. (22.2 kg)

¹ASSUMES 12" (305 mm) STONE ABOVE, 9" (229 mm) STONE FOUNDATION, 6" (152 mm) STONE BETWEEN CHAMBERS, 6" (152 mm) STONE PERIMETER IN FRONT OF END CAPS AND 40% STONE POROSITY.

PARTIAL CUT HOLES AT BOTTOM OF END CAP FOR PART NUMBERS ENDING WITH "B"
PARTIAL CUT HOLES AT TOP OF END CAP FOR PART NUMBERS ENDING WITH "T"
END CAPS WITH A PREFABRICATED WELDED STUB END WITH "W"
END CAPS WITH A WELDED CROWN PLATE END WITH "C"

PART #	STUB	B	C
MC3500EPP08T	6" (150 mm)	33.21" (844 mm)	---
MC3500EPP08B	6" (150 mm)	---	0.66" (17 mm)
MC3500EPP08T	8" (200 mm)	31.16" (793 mm)	---
MC3500EPP08B	8" (200 mm)	---	0.81" (21 mm)
MC3500EPP10T	10" (250 mm)	29.04" (738 mm)	---
MC3500EPP10B	10" (250 mm)	---	0.93" (24 mm)
MC3500EPP12T	12" (300 mm)	26.35" (670 mm)	---
MC3500EPP12B	12" (300 mm)	---	1.35" (34 mm)
MC3500EPP15T	15" (375 mm)	23.39" (594 mm)	---
MC3500EPP15B	15" (375 mm)	---	1.60" (41 mm)
MC3500EPP18T	18" (450 mm)	20.03" (509 mm)	---
MC3500EPP18B	18" (450 mm)	---	1.77" (45 mm)
MC3500EPP24TC	24" (600 mm)	14.48" (368 mm)	---
MC3500EPP24TW	24" (600 mm)	---	2.06" (52 mm)
MC3500EPP24BC	30" (750 mm)	---	2.75" (70 mm)
MC3500EPP30BC	30" (750 mm)	---	---

NOTE: ALL DIMENSIONS ARE NOMINAL

ADS STORMTECH MC-3500 TECHNICAL SPECIFICATIONS
NOT TO SCALE

BASIN ELEVATIONS			
BASIN ID	TOP OF BERM ELEV. A	TOP OF SPILLWAY ELEV. B	BOTTOM OF BASIN ELEV. C
SWM-B	94.80	94.30	91.00
SWM-D	100.10	99.10	97.50

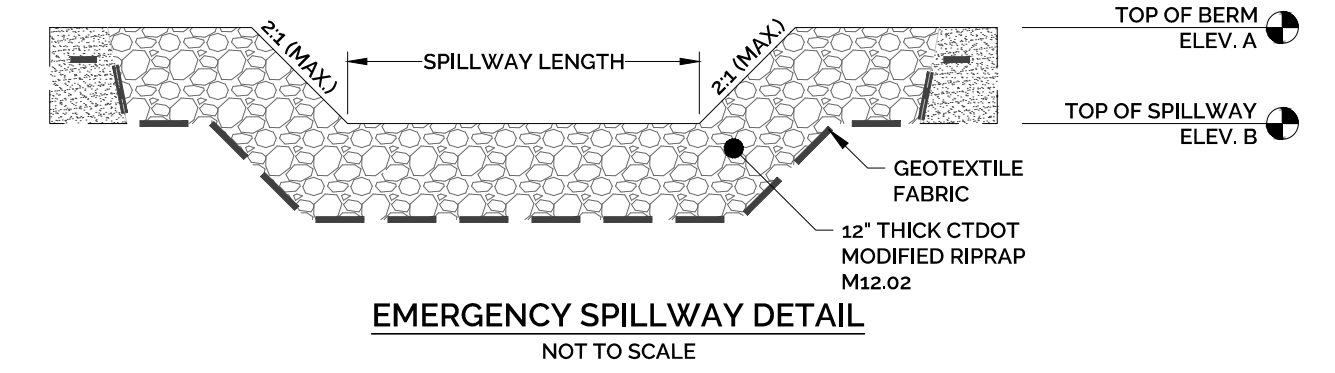

EMERGENCY SPILLWAY DETAIL
NOT TO SCALE

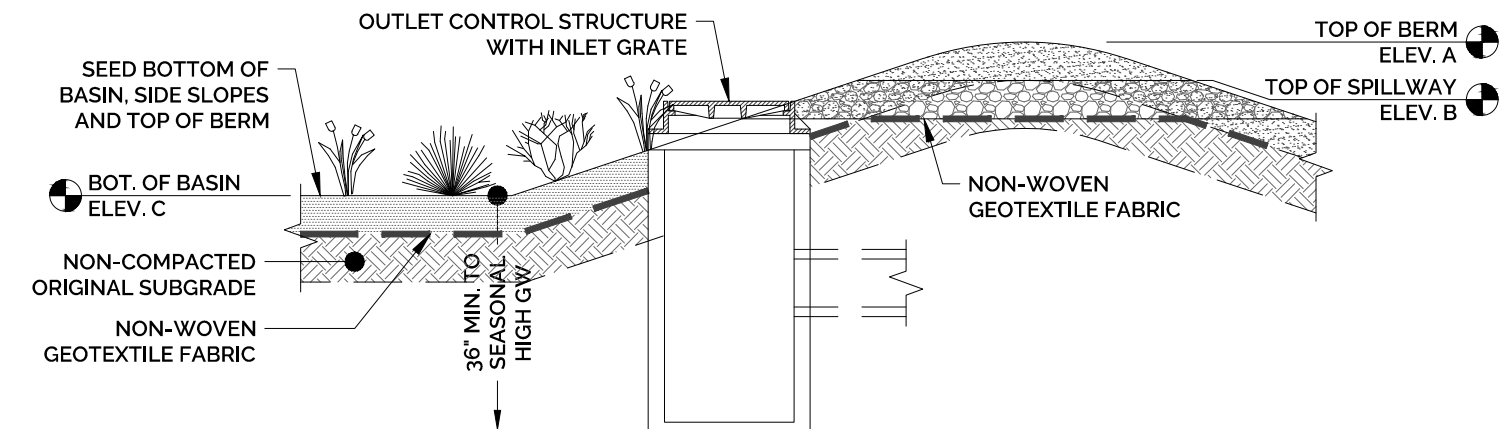

BIORETENTION BASIN CONSTRUCTION SEQUENCE

- REMOVE EXISTING TOPSOIL, SURFACE LEAF LITTER, ETC. FROM BIORETENTION BASIN AREA AND STOCKPILE FOR REUSE.
- AVOID COMPACTION OF NATURAL SOILS WITHIN BOTTOM AREA OF BIORETENTION BASIN BY CONSTRUCTION EQUIPMENT. THE AREA OF THE BIORETENTION BASIN SHALL BE MARKED OFF BY APPROPRIATE FENCING TO PREVENT THE MOVEMENT OF CONSTRUCTION VEHICLES OVER AND THE POSSIBLE COMPACTION OF THE NATURAL SOILS.
- SCARIFY NATURAL SOILS WITHIN THE BOTTOM OF BASIN PRIOR TO PLACING STOCKPILE TOPSOIL.
- ALL DISTURBED AREAS SHALL BE FINE GRADED WITH 6" TOPSOIL. RAKED, SEEDED AND MULCHED IN A TIMELY MANNER. TOPSOIL SHALL BE PLACED IN THE BASIN USING LIGHT EQUIPMENT. ALLOW SOIL TO SETTLE NATURALLY THROUGH RAIN EVENTS OR PRESOAK AFTER PLACEMENT.
- PLANT TREES AND SHRUBS AS SPECIFIED BY THE LANDSCAPE ARCHITECT.
- PLACE A 3-INCH LAYER OF WELL-AGED SHREDDED HARDWOOD FREE OF ROOTS, SOIL AND WEEDS.
- SEED BOTTOM OF BASIN, SIDE SLOPES AND TOP OF BERM WITH CONSERVATION/WILDLIFE MIX AT 1 LB/1.750 S.F., OR EQUIVALENT. SEEDING SHALL BE QUICKLY ESTABLISHED AND MAINTAINED TO PREVENT ANY SILT ACCUMULATION ALONG THE BOTTOM OF THE BASIN. MINIMUM VEGETATIVE COVERAGE OF 90% SHALL BE TARGETED AND MAINTAINED.
- BIORETENTION BASIN SHALL NEVER BE USED FOR SEDIMENT CONTROL DURING AN ACTIVE CONSTRUCTION PERIOD.
- DURING CONSTRUCTION, SEDIMENT SHALL BE PREVENTED FROM ENTERING THE AREA OF THE BASIN. THE CONTRACTOR SHALL ENSURE THAT THE AREAS DRAINING TO THE BIORETENTION BASIN ARE STABILIZED IN A TIMELY MANNER AND MAINTAINED OVER THE ENTIRE AREA DRAINING TO THE BASIN.

BIORETENTION BASIN DETAILS

NOT TO SCALE

INLET/OUTLET CONTROL STRUCTURE ELEVATION SUMMARY TABLE							
STRUCTURE ID	TOP OF FRAME ELEV. A	TOP OF WEIR PLATE ELEV. B	UPPER ORIFICE INVERT ELEV. C	LOWER ORIFICE INVERT ELEV. D	INLET PIPE INVERT ELEV. E	OUTLET PIPE 1 INVERT ELEV. F	OUTLET PIPE 2 INVERT ELEV. G
ICS-1	91.35	89.25 (RESTRICT FLOW TO OVERFLOW)	---	---	85.90 (12") (E)	86.86 (12") ISOLATOR ROW (W)	86.86 (12") OVERFLOW (N)
ICS-2	93.30	91.05 (RESTRICT FLOW TO OVERFLOW)	---	---	87.70 (12") (E)	87.66 (12") ISOLATOR ROW (W)	87.66 (12") OVERFLOW (N)
ICS-3	93.50	91.45 (RESTRICT FLOW TO OVERFLOW)	---	---	88.10 (12") (S)	88.06 (12") ISOLATOR ROW (W)	88.06 (12") OVERFLOW (N)
ICS-4	95.00	92.25 (RESTRICT FLOW TO OVERFLOW)	---	---	88.90 (12") (E)	88.86 (12") ISOLATOR ROW (W)	88.86 (12") OVERFLOW (N)
OCS-1	92.70	89.35 (RESTRICT FLOW TO OVERFLOW)	88.50 (6" DIA.)	87.70 (4" DIA.)	86.86 (12" MANIFOLD) (S)	85.80 (12") (W)	---
OCS-2	94.20	91.05 (RESTRICT FLOW TO OUTLET)	89.55 (6" DIA.)	88.95 (4" DIA.)	87.66 (12") (N & E)	87.60 (12") (S)	---
OCS-3	94.50	91.45 (RESTRICT FLOW TO OUTLET)	90.60 (6" DIA.)	89.55 (4" DIA.)	88.06 (12") (S & E)	88.00 (12") (N)	---
OCS-4	96.25	92.25 (RESTRICT FLOW TO OUTLET)	91.20 (6" DIA.)	90.35 (4" DIA.)	88.86 (12") (N)	88.80 (12") (E)	---
OCS-5	93.60	---	---	---	92.75 (6" DIA.)	---	89.00 (12") (S)
OCS-6	95.50	90.75 (RESTRICT FLOW TO OUTLET)	---	---	89.75 (4" DIA.)	87.40 (6") (N & S)	87.20 (6") (E)

INLET CONTROL STRUCTURE (ICS) AND OUTLET CONTROL STRUCTURE (OCS)
NOT TO SCALE

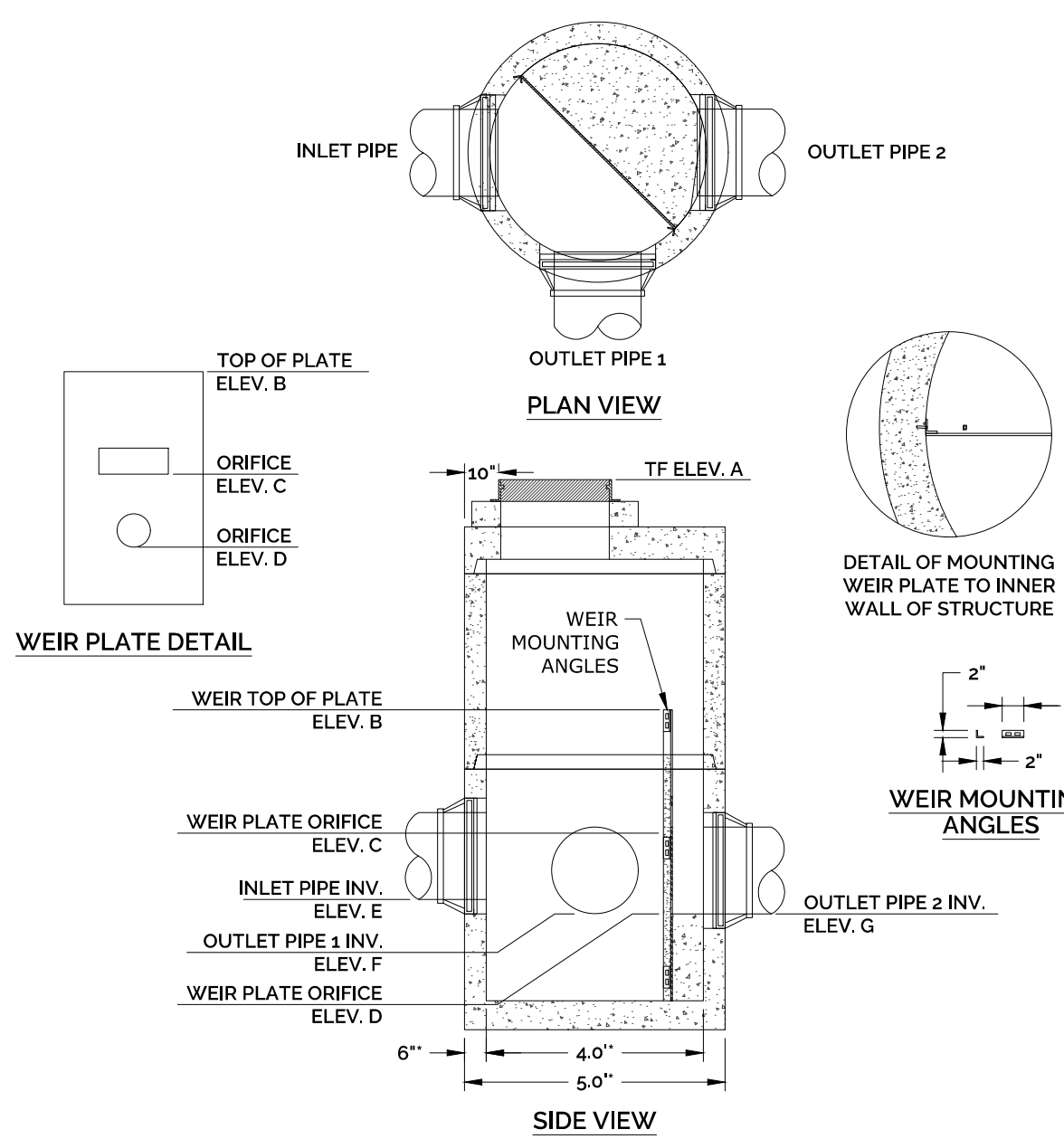

NOTES:

- 5" OR 6" DIA. PRECAST BASES MAY BE USED WHEN REQUIRED DUE TO SIZE OR NUMBER OF PIPES AT THE MANHOLE. PRECAST REDUCERS WILL BE PLACED ABOVE THE 4" AND 6" BASES. WALL THICKNESS TO INCREASE 1" FOR EACH 1" OF INSIDE DIAMETER INCREASE.

INLET/OUTLET CONTROL STRUCTURE DETAIL
NOT TO SCALE

REV	DESCRIPTION OF REVISION	DATE	APPR.	CHKD.
1	REVISED PER ENGINEERING REVIEW COMMENTS & IWA COMMENTS	3/17/2023		
2	REVISED PER ENGINEERING REVIEW COMMENTS	2/24/2023		

STORMWATER MANAGEMENT DETAILS
VESSEL MULTI-FAMILY HOUSING
PROPERTY ADDRESS
446 HOPMEADOW STREET, SIMSBURY, CT 06089
PREPARED FOR
VESSEL RE HOLDINGS, LLC
46 WEST 55TH STREET, NEW YORK, NY 10019

PROJECT NO.	SCALE
2022-0013	NOT TO SCALE
DRAWN BY:	DATE
SMM	12/16/2022
CHECKED BY:	DATE
SMM	12/16/2022