

- NOTE:
1. WOOD POSTS SHALL BE HARDWOOD 1 1/2" x 1 1/2" x 42" MIN. STEEL POST SHALL BE A MINIMUM OF 0.5 POUNDS PER LINEAR FOOT X 42".
 2. JOINTS, WHEN REQUIRED, SHALL BE SPLICED & SECURELY SEALED TOGETHER, AT POST LOCATIONS ONLY, WITH A MINIMUM 6" OVERLAP.

SEDIMENTATION CONTROL SYSTEM INSTALLATION
NO SCALE

LEGEND

	APPROXIMATE PROPERTY LINE
	EXISTING TREE LINE
	PROPOSED LIMIT OF CLEARING
	EXISTING ELEVATION CONTOUR
	EDGE OF BROOK
	LIMIT OF INLAND WETLANDS
	APPROXIMATE FLOOD ZONE LINE
	PROPOSED SILT FENCE
	CATCH BASIN
	EXISTING SPOT GRADE
	PROPOSED SPOT GRADE
	BITUMINOUS

- REFERENCE MAPS:**
1. "MEADOWVIEW, 971 HOPMEADOW STREET & 1-31 COUNTRY LANE, MAP OF LAND FOR UDOLF ENTERPRISES, LLC, HOPMEADOW STREET, SIMSBURY, CONN., SCALE 1"=30', APR. 11, 1995, ADDITIONS THROUGH MAY 19, 1995", BY ABRAHAM H. FIENSTEIN.
 2. "OWEN'S GATE, OPEN SPACE TO BE DEEDED TO TOWN OF SIMSBURY BY RAYMOND J. & VICTOR I. CARNELLI AND LOUIS SPERANDIO, SIMSBURY, CONNECTICUT, SCALE 1"=100', SEPT. 6, 1966, JOHN T. WELLS, REG. LAND SURVEYOR".

- NOTES:**
1. THIS SURVEY HAS BEEN PREPARED PURSUANT TO THE REGULATIONS OF CONNECTICUT STATE AGENCIES SECTIONS 20-300b-1 THROUGH 20-300b-20, AS REVISED.
- TYPE OF SURVEY: TOPOGRAPHIC SURVEY
CLASS OF HORIZONTAL ACCURACY: D
CLASS OF TOPOGRAPHIC ACCURACY: T-2
2. ELEVATIONS ARE BASED ON ASSUMED DATUM.
 3. THIS MAP IS VALID ONLY IF IT BEARS THE ORIGINAL SIGNATURE AND EMBOSSED SEAL OF THE UNDERSIGNED LAND SURVEYOR.
- TO MY KNOWLEDGE AND BELIEF, THIS MAP IS SUBSTANTIALLY CORRECT AS NOTED HEREON.

SURVEYOR'S SIGNATURE DATE: 6-7-2021 LICENSE NUMBER: 14649

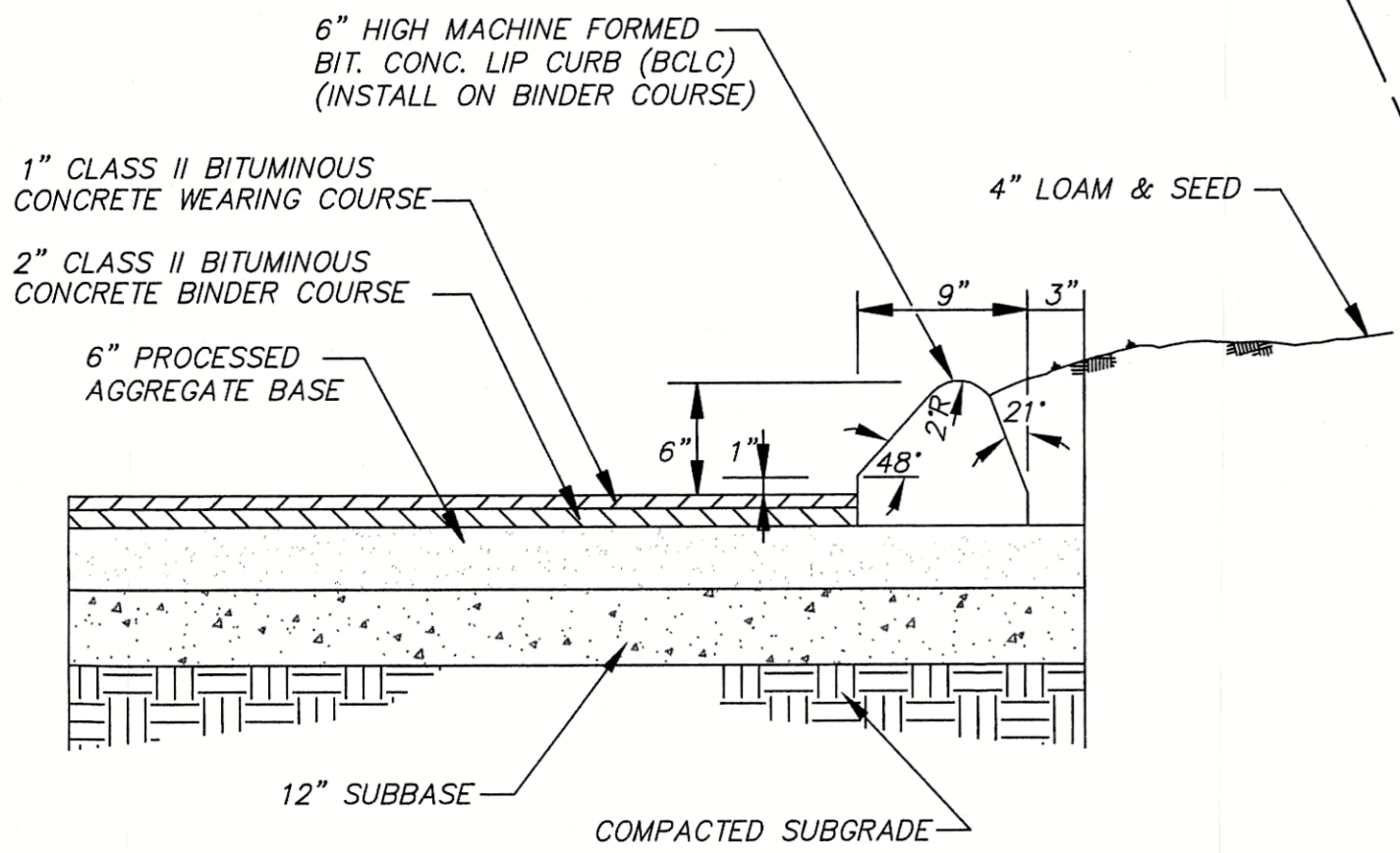

BITUMINOUS CONCRETE LIP CURBING (BCLC)
NO SCALE

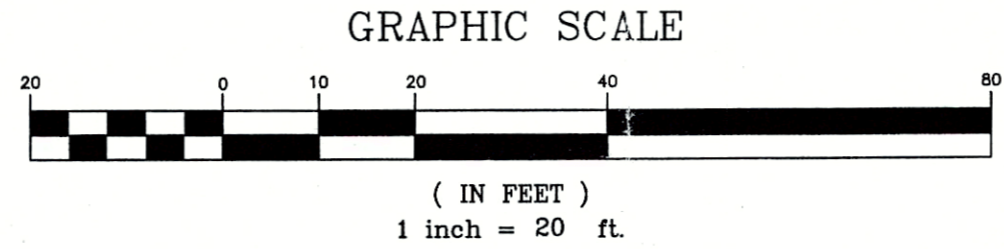

THIS DRAWING HAS BEEN PREPARED BASED, IN PART, ON INFORMATION PROVIDED BY OTHERS RELATING TO THE LOCATION OF UNDERGROUND SERVICES. WE CAN NOT VERIFY THE ACCURACY OF THIS INFORMATION AND SHALL NOT BE HELD RESPONSIBLE FOR ANY ERRORS OR OMISSIONS WHICH MAY BE INCORPORATED HEREIN AS A RESULT.

INDICATED UNDERGROUND UTILITIES ARE BASED ON AVAILABLE DATA. THE LOCATIONS ARE APPROXIMATE AND ALL UTILITIES MAY NOT BE SHOWN. CALL "CALL B-4-U DIG" AT 1-800-922-4455 PRIOR TO ANY EXCAVATION.

TOPOGRAPHIC SURVEY
PREPARED FOR
UDOLF ENTERPRISES, LLC
971 HOPMEADOW STREET
SIMSBURY, CONNECTICUT

Date: 6-6-21
Drawn: DJD
Checked: AB

Scale: 1"=20'
WETLANDS & PARKING LINE

THE BONGIOVANNI GROUP, INC.
LAND SURVEYORS
140 Park Road
Newington, Conn. 06111
TEL: (860) 666-0134
FAX: (860) 666-3830

6-2-21

20180-1-WKS.DWG 20180